



Remote Control | Remote Monitoring | Industrial Automation
Data Acquisition | Temperature Monitoring | Security Monitoring
Equipment Control | Weather Station Monitoring

Introduction

ControlByWeb™ products are high-end components for remote monitoring and control applications. Companies, organizations, and individuals use our products to monitor and control many different types of equipment and systems in real-time from any computer using a web browser. Our products can be used as stand-alone devices in simple applications, offering a complete solution requiring no additional equipment. They can also be used as building-blocks in large systems.

How They Work

Each ControlByWeb product has a small combination of I/O (inputs & outputs) and a built-in web server. Sensors, switches, voltages, etc., can be connected to the inputs for monitoring various parameters, conditions, or events of interest such as temperatures, voltages, or alarms.

Outputs (usually relays) can be used to control just about anything, including lights, bells, motors, computers, heating systems, etc. Because our products have a built-in web server, users can view input parameters and control relay outputs using a simple web page from just about any web browser. In addition, our products support multiple protocols so they can communicate directly with computers, PLCs, and automation controllers in more advanced control systems.

Example Applications

ControlByWeb products are used to monitor temperature, humidity, power, tank levels, pressure, the status of doors, windows, production machines, and much more. Our products are also used to control computers (remote reboot), communications equipment, lights, bells, motors, pumps, HVAC units, signs, gates, and much more.

Why ControlByWeb™

ControlByWeb products are designed to be extremely robust and reliable. Although they are affordably priced, no shortcuts were taken in their design, and no compromises were made in the parts used. Some would say that our products are “over engineered” because there are many internal parts that could be replaced with less expensive versions or even removed to save money, but we believe it’s more important to build them right than to build them cheap.

Our products are carefully made in the USA at our own facilities and each product is inspected many times at different levels of production and tested before it is shipped. Our firmware is tested both manually and automatically for long time periods to verify its integrity before it is released. Our staff is very knowledgeable and we are interested in doing whatever we can to make sure all projects that use our products are successful. These are just a few reasons to choose ControlByWeb.

Table of Contents

WebRelay™	1
WebRelay Wireless™	3
X-401™	5
X-404™	7
X-405™	9
X-406™	11
X-408™	13
X-410™	15
X-418™	17
X-420™	19
WebRelay-Quad™	21
X-300™	23
X-317™	25
X-332™	27
X-400™	29
X-600M™	31
X-11s™	33
X-12s™	35
X-13s™	37
X-15s™	39
X-16s™	41
X-17s™	43
X-18s™	45
X-19s™	47
X-20s™	49
X-21s™	51
X-22s™	53
XW-110™	55
XW-110 Plus™	57
XW-111™	59
XW-112™	61
WebRelay-10™	63
WebRelay-10 Plus™	65
WebSwitch™	67
WebSwitch Plus™	69
Feature Comparison	71
Trademark and Copyright Information	74
Warranty	74

PRODUCT OVERVIEW

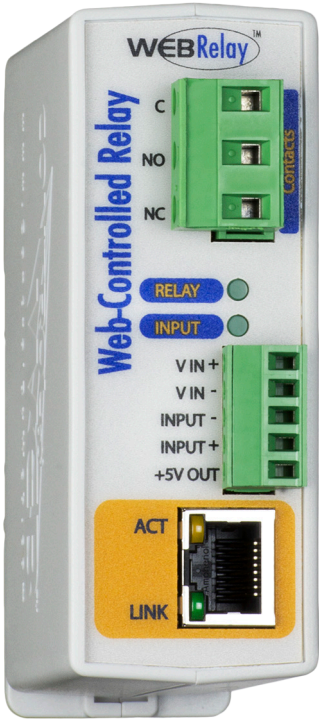

WebRelay™ provides reliable remote relay control and discrete signal monitoring over any IP network.

WebRelay can be used in countless applications, including pump and motor control, security lock systems, remote reboot, and lighting control.

WebRelay's powerful and flexible design make imagination its only limit.

In addition to its built-in relay, WebRelay has an optically-isolated input that can be used to monitor the state of devices, control the relay, or control a remote relay somewhere else on the network.

This feature is useful to extend the output of a PLC to another building, or to allow a switch or sensor to control a device at a distant location.

Features:

- No programming required.
- Full control using a standard web browser or text-based XML messages.
- Can operate as a Modbus TCP/IP slave.
- Password protected.
- 12-Amp relay contacts.
- On/Off and Pulse modes.
- Optically-isolated input can be used for:
 - Monitoring
 - Relay control
 - Remote relay control (Peer to Peer)
 - Automatic Reboot controller mode for remote reboot of computers and network devices.
- Selectable TCP ports.
- Two removable terminal connectors included.
- Rugged DIN-Rail/wall mountable enclosure.
- Two power supply options available:
 - 9-28 VDC
 - Power-Over-Ethernet (802.3af) or 5VDC



Setup

Network	Password	Relay/Input	Control Page Setup	Relay Control Page
Relay/Input:				
Relay Mode:	Standard <input checked="" type="radio"/> Automatic Reboot <input type="radio"/>			
Ping IP Address:	192 . 168 . 1 . 15			
Successful Ping Period:	60 secs			
Unsuccessful Ping Period:	10 secs			
Delay Before First Ping After Reboot:	120 secs			
Reboot Timer 1 (T1):	10 secs			
Reboot Timer 2 (T2):	5 secs			
Reboot Timer 3 (T3):	2 secs			
Reboot Options:	pulse off T1 secs			
Failed Pings Before Reboot:	5			
Max Reboot Attempts:	10			
Remote Relay Options:	no remote relay control			
Remote Relay IP Address:	192 . 168 . 1 . 3			
Remote TCP Port:	80			
Relay #:	0			
Password:	••••••••			
Keep Alive:	YES(No TX State)			
<input type="button" value="Submit"/> <input type="button" value="Reset"/>				

Automatic Reboot Options

Relay Options

APPLICATIONS & SPECS

Shift Bell Controller

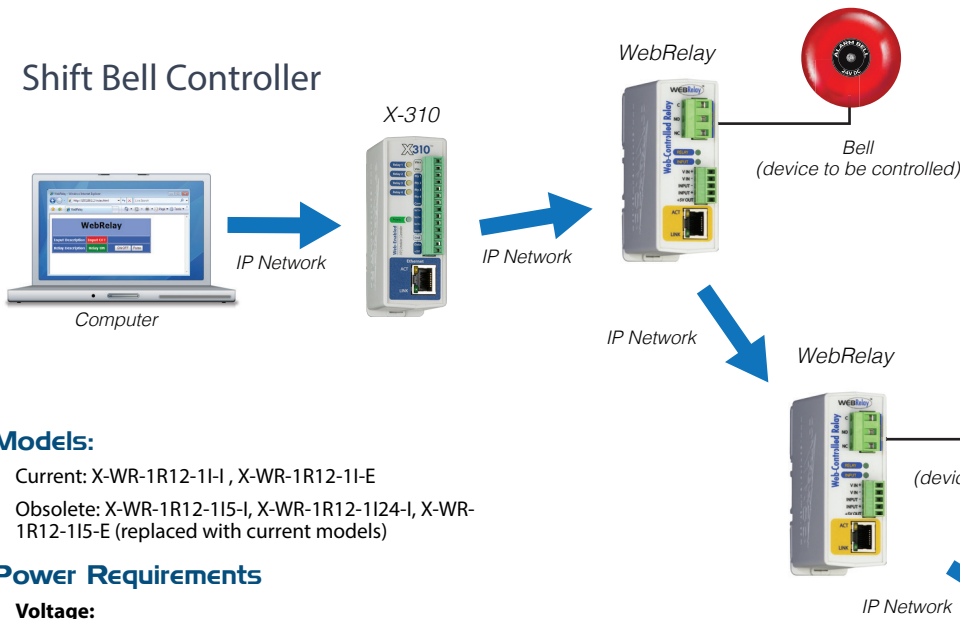

Additional Applications

- ✓ Remote Reboot
- ✓ Pump Control
- ✓ Motor Control
- ✓ Remote Relay
- ✓ Remote PLC Control
- ✓ Home Automation
- ✓ Industrial Automation
- ✓ More...

Models:

- Current: X-WR-1R12-11-I, X-WR-1R12-11-E
- Obsolete: X-WR-1R12-115-I, X-WR-1R12-1124-I, X-WR-1R12-115-E (replaced with current models)

Power Requirements

- **Voltage:**
 - X-WR-1R12-11-I: 9-28VDC
 - X-WR-1R12-11-E: POE and/or 9-28VDC
 - X-WR-1R12-115-I: 9-28VDC
 - X-WR-1R12-1124-I: 9-28VDC
 - X-WR-1R12-115-E: POE Class 1 (0.44 to 3.84 Watt) or 5V±5%
- **Current:** 313 mA Max

Relays

- **Number of Relays:** 1
- **Max Voltage:** 240VAC, 30VDC
- **Max Current:** 12A
- **Contact Type:** SPDT (Form 1C)
- **Load Type:** General Purpose
- **Contact Resistance:** < 30 milliohms initial
- **Contact Material:** AgSnO2
- **Electrical Life:** 100K cycles (Typical)
- **Mechanical Life:** 10M cycles (Typical)
- **Environmental Rating:** Over voltage Category II, Pollution Degree 2
- **Relay Modes:** ON/OFF or Pulsed
- **Pulse Timer Duration:** 0.1 to 86,400 Seconds (1-day)

Digital Inputs

- **Number of Inputs:** 1
- **Type:** Optically-Isolated
- **Voltage Range:**
 - X-WR-1R12-11-I: 4-26 VDC
 - X-WR-1R12-11-E: 4-26 VDC
 - X-WR-1R12-115-I: 4-12VDC
 - X-WR-1R12-1124-I: 11-26VDC
 - X-WR-1R12-115-E: 4-12VDC
- **Current:**
 - X-WR-1R12-11-I: 950uA @ 4V, 8.5mA @ 26V
 - X-WR-1R12-11-E: 950uA @ 4V, 8.5mA @ 26V

- X-WR-1R12-115-I: 4mA @ 4V, 16mA @ 12V
- X-WR-1R12-1124-I: 3.2mA @ 11V, 8.2mA @ 26V
- X-WR-1R12-115-E: 4mA @ 4V, 16mA @ 12V
- **Minimum Hold Time:** 25mS
- **Input Isolation:** 1500Vrms
- **Input Functions:** Monitor, Local Relay Control, Remote Relay Control

Network

- **Type:** 10/100 Base-T Ethernet Port
- **Setup:** Static IP address assignment. TCP port selectable

Connectors

- **Power/Input:** 5-Position Removable
- **Relays/Inputs:** 3-Position Removable
- **Network:** 8-pin RJ-45

LED Indicators

- **Number of LEDs:** 4
 - Digital input voltage applied
 - Relay coil energized
 - Network linked
 - Network activity

Physical

- **Operating Temperature:** -40°F to 150°F (-40°C to 65.5°C)
- **Size:**
 - 1.41in (35.7mm) wide
 - 3.88in (98.5mm) tall
 - 3.1in (78mm) deep (not including connector)
- **Weight:** 5 oz (142 grams)
- **Enclosure Material:** Lexan 940 Polycarbonate Plastic
- **Enclosure Flame Rating:** UL94 V0

Protocols

- HTTP, XML, Modbus TCP/IP

Logging

- **Log File Size:** 512K (max 28,829 logs)
- **Storage:** Nonvolatile Flash
- **Buffer Architecture:** Circular Buffer
- Log data can be periodically read and stored on a computer

Advanced Features

- BASIC interpreter
- Remote services - Avoid most firewall issues with outbound connection to Web Services

Password Settings

- **Password protection on setup page:** Yes
- **Password protection on control page:** Optional
- **Password Encoding:** Base 64
- **Max Password Length:** 10 Characters

Electromagnetic Compliance

- IEC CISPR 22, CISPR 24
- EU EN55024, EN55022
- FCC 47CFR15 (-I Models class B, -E POE Model Class A)

Product Safety Compliance

- UL 61010-1 (Electrical Equipment for Measurement, Control, and Laboratory Use) - Models: X-WR-1R12-11-I and X-WR-1R12-11-E



PROCESS CONTROL EQUIPMENT
E468316

PRODUCT OVERVIEW



The WebRelay Wireless™ is an easy to use Wi-Fi enabled relay, temperature monitor and status alerting device. The WebRelay Wireless has a built-in relay for controlling lights, motors and other relatively high current loads, a digital input which can be used to monitor and report the status of switch-closure sensors and a “1-Wire” port for connecting up to four digital temperature or other Xytronix 1-wire sensors.

The WebRelay Wireless works well as a standalone device that can be controlled using a web browser. It can be configured using simple menus and drop-down lists. It includes features such as logging, input state monitoring, and the ability to control other relays on other devices.

The WebRelay Wireless can be a self-contained wireless access point that requires no additional servers or ControlByWeb devices. In this mode the WebRelay Wireless provides live, real-time temperatures or input status directly to a user through web browsers or the CBW Mobile app (optional).

Setup is simple. There is no app to download, no subscription to buy, no software required, and no programming necessary for setup or use.

The WebRelay Wireless is ideal for applications where devices must be controlled or where temperature or events

must be monitored and Ethernet wiring is not accessible or practical to install. The module is powered by an external wall transformer (9-28 VDC), solar panel, or other DC power source.

Features:

- Built-in high current relay
- Optically-isolated digital input
- Up to 4 temperature sensors
- Wireless Wi-Fi 802.11 b/g/n
- Transmission range up to 250ft
- Real-Time clock with NTP server synchronization
- Automatic daylight savings and leap year adjustment
- No software required
- Customizable web-based control page
- BASIC script support for advanced flexibility
- Configurable logging of the input, counter, temperature, humidity, relay state, and Vin
- Send email alerts (up to 8 email addresses) based on user-defined conditions
- Supports encrypted email servers, such as Gmail
- Static or DHCP IP address configuration
- XML, Modbus/TCP and Remote Services
- Field updatable
- Removable terminal connectors for easy installation
- Rugged DIN-Rail/wall-mountable enclosure
- 5-Year Warranty

WebRelay Wireless		
Relay 1	ON	ON OFF PULSE
Input 1	OFF	
Counter 1	0.000	Reset Count
Sensor 1	67.4 °F	
Sensor 2	67.6 °F	
Sensor 3	67.3 °F	
Sensor 4	67.4 °F	
Register1	ON	ON OFF
Register2	OFF	ON OFF
Register3	OFF	ON OFF
Register4	OFF	ON OFF

Control Page Options

APPLICATIONS & SPECS

Power Requirements

- **Voltage:** 9-28 VDC
- **Max Current:** 188 mA

Wireless

- **Network Standards:** IEEE 802.11 b/g/n
- **Frequency Band:** 2.412 - 2.462 GHz
- **Wi-Fi Security Standards:** Open, WEP, WPA, WPA2
- **Network Settings:** DHCP or Static
- **Wireless Range:** Up to 250ft (typical for Wi-Fi devices) depends on environment
- **Antenna:** External, 2.4 GHz, 50Ohm, omni directional, 1/4 wavelength, gain: ≤ 2.1 dBi. With articulated reverse SMA connector.
- **RF Output Power (typ):** 14dBm (802.11b/g), 12dBm (802.11n)

Operation

- **Provisioning:** Via internal web server (no cables or PC utilities needed)
- **Access Point:** Yes, push button activated (setup via web page)
- **WPS:** Yes, push button activated (Wi-Fi Protected Setup)
- **Connectivity:** Intermittently connected or always connected
- **XCD Data Packet:** UDP, 10-bytes (See Appendix A)
- **Remote Server:** ControlByWeb's X-600M™, X-300™ or cloud-based server
- **Polling:** state.xml (only with always-connected)

Relays

- **Number of Relays:** 1
- **Max Voltage:** 277VAC, 30VDC
- **Max Current:** 12A
- **Contact Type:** SPDT (Form 1C)
- **Load Type:** General Purpose
- **Contact Resistance:** < 30 milliohms initial
- **Contact Material:** AgSnO2
- **Electrical Life:** 100K cycles (Typical)
- **Mechanical Life:** 10M cycles (Typical)
- **Environmental Rating:** Over voltage Category II, Pollution Degree 2
- **Relay Modes:** ON/OFF or Pulsed
- **Pulse Timer Duration:** 0.1 to 86,400 Seconds (1-day)

Digital Inputs

- **Number of Inputs:** 1
- **Type:** Optically-Isolated
- **Voltage Range:** 4-26 VDC
- **Current:** 950uA @ 4V, 8.5mA @ 26V
- **Minimum Hold Time:** 25mS
- **Input Functions:** Monitor, Local Relay Control, Remote Relay Control
- **Maximum Count:** 24-bit
- **Max Count Rate:** 20Hz Max (Dependent on Configuration)
- **Edge Trigger:** Rising, Falling or Both

Gate Controller

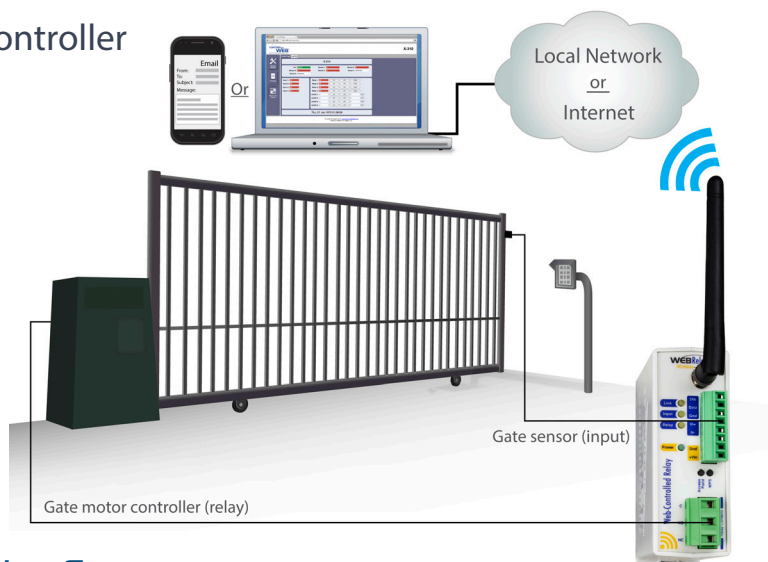

Temperature Sensors

- **Maximum Number of Sensors:** 4
- **Type:** Dallas Semiconductor DS18B20
- **Temperature Range:** -67°F to 257°F (-55°C to +125°C)
- **Accuracy:** $\pm 0.5^\circ\text{C}$ (from -10°C to $+85^\circ\text{C}$)
- **Sensor Functions:** Monitor Temperature, Email Alerts, Control Relays
- **Humidity Type:** Xytronix Model X-DTHS-P sensor
- **Humidity Range:** 0-100% RH
- **Accuracy:** $\pm 2\%$

Real-Time Clock

- Manual or NTP(Network Time Protocol) setup
- **NTP Sync Period:** Once, Daily, Weekly, On Power-up
- Auto Daylight Savings Adjustment

Network

- **Type:** 10/100 Base-T Ethernet Port
- **Setup:** Static IP address assignment. TCP port selectable

Connectors

- **Power/Input/Temperature:** 5-Position Removable
- **Relays/Inputs:** 3-Position Removable
- **Network:** 8-pin RJ-45

Push Buttons

- **Button 1:** Force access-point mode
- **Button 2:** Activate WPS mode

LED Indicators

- **Number of LEDs:** 4
 - Power on
 - Relay coil energized
 - Digital Input
 - Network linked

Physical

- **Operating Temperature:** -40°F to 150°F (-40°C to 65.5°C)
- **Size:**

- 1.41 in (35.7mm) wide
- 3.88in (98.5mm) tall
- 3.1in (78mm) deep (not including connector)
- **Weight:** 5 oz (142 grams)
- **Enclosure Material:** Lexan 940 Polycarbonate Plastic
- **Enclosure Flame Rating:** UL94 V0

Protocols

- HTTP, XML, SSL, Modbus TCP/IP, SMTP, Remote Services

Logging

- **Log File Size:** 512K (max 28,829 logs)
- **Storage:** Nonvolatile Flash
- **Buffer Architecture:** Circular Buffer
- *Log data can be periodically read and stored on a computer*

Advanced Features

- BASIC interpreter
- Remote services

Password Settings

- **Password protection on setup page:** Yes
- **Password protection on control page:** Optional
- **Password Encoding:** Base 64
- **Max Password Length:** 13 Characters

Electromagnetic Compliance

- FCC ID: 2AE4Z-XWD002
- FCC 47CFR15 (Class B)
- IEC CISPR 22, CISPR 24
- EN55024 ITE Immunity (2010)
- EN55022 Emissions (2010)
- IC: 21441-XWD002
- EMC95120-ETSI328 (Australia)
- EMC95120-IEC62311 (Australia)



Product Safety Compliant

- UL 61010-1 (Electrical Equipment for Measurement, Control, and Laboratory Use)

PROCESS CONTROL EQUIPMENT
E468316

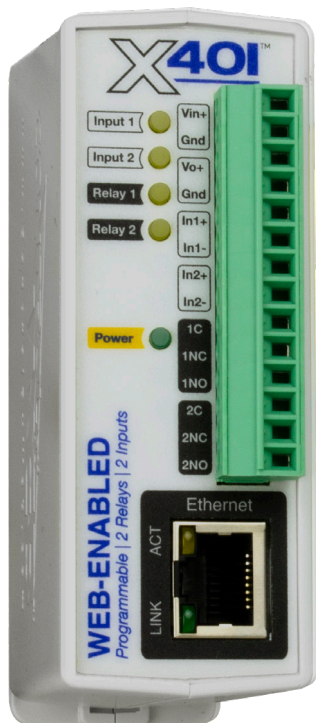

The X-401™ is an exciting component in our most advanced series of products.

It is a robust, full-featured, web-enabled, mini Ethernet I/O module with two 3-Amp relays and two optically-isolated digital inputs plus all of the advanced features from our 400-series products.

It has non-volatile memory for logging, a real-time clock with support for NTP (time server) synchronization and an advanced scheduler which can be used to turn on/off relays at preset times.

Its web-based user interface means it can be used right out of the box with no programming required.

The X-401™ has many advanced features including a simple firewall, the ability to initiate a connection to remote servers, BASIC programming, SNMP, email alerts,

peer-to-peer communications, internal monitoring, and more.

The X-401™ is ideal for many applications, including security, remote control, street sign controllers, shift bell controllers, and much more.

Features:

- 2 Electro-mechanical relays
- Two optically-isolated digital inputs
- Peer-to-peer communications between 4xx Series modules which provides seamless I/O sharing
- User Permissions: Admin, Manager, User
- Programmable tasks for scheduled events or conditional logic
- Send email alerts based on user-defined conditions (supports encrypted email servers, such as Gmail)
- Real-Time Clock with NTP server synchronization
- Automatic daylight savings and leap year adjustment
- Customizable web-based Control Page
- BASIC script support for advanced flexibility
- Configurable logging
- Graphing (logged data)
- HTTPS/TLS encrypted
- Static or DHCP IP address configuration
- Modbus, SNMP, Remote Service, IP Filtering
- No software required
- Removable 14-Terminal connector for easy installation
- Rugged DIN-Rail/wall-mountable enclosure

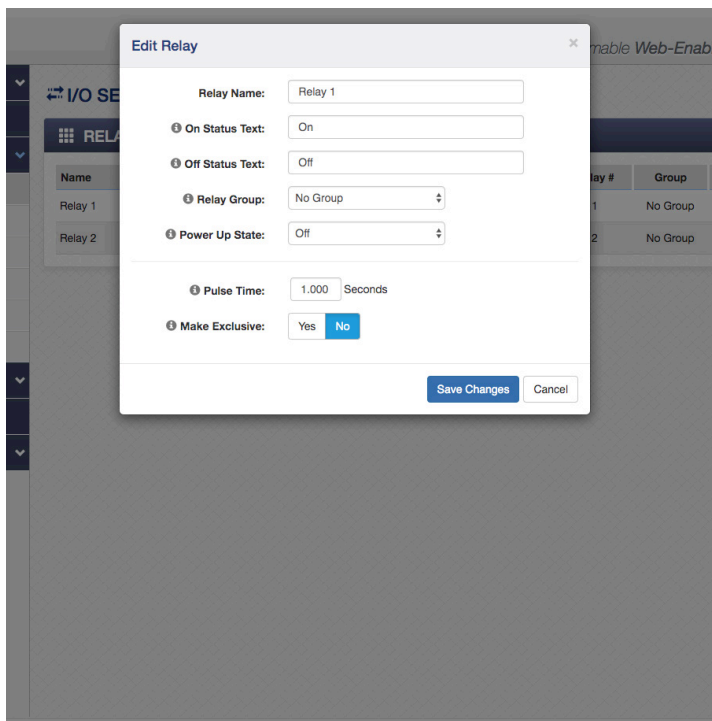

Relay Options Page

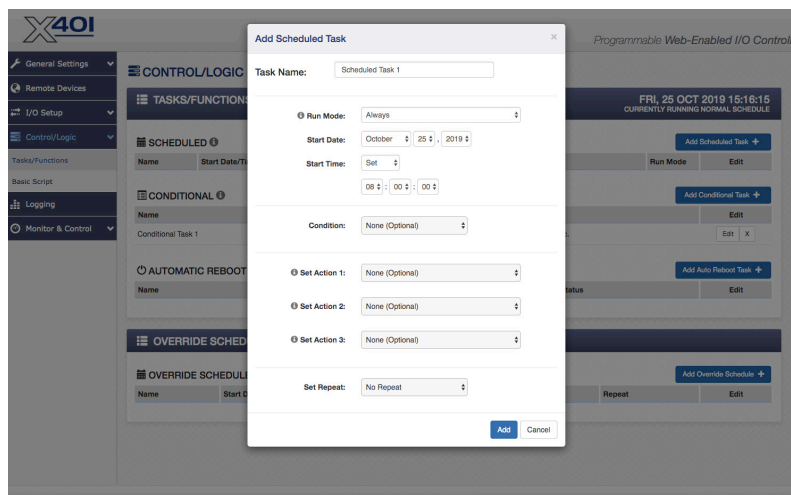

Event Scheduling Page

APPLICATIONS & SPECS

Shift Bell Controller



Models:

- X-401-I, X-401-E

Power Requirements

- **Voltage:**
 - X-401-I: 9-28VDC
 - X-401-E: POE and/or 9-28 VDC
- **Current:** 233mA Max

Relays

- **Number of Relays:** 2
- **Max Voltage:** 28VAC, 24VDC
- **Max Current:** 3A
- **Contact Type:** SPDT (Form C)
- **Load Type:** General Purpose
- **Contact Resistance:** < 50 milliohms initial
- **Contact Material:** AgSnO2
- **Electrical Life:** 100K cycles (Typical)
- **Mechanical Life:** 10M cycles (Typical)
- **Environmental Rating:** Over voltage Category II, Pollution Degree 2
- **Relay Modes:** ON/OFF or Pulsed
- **Pulse Timer Duration:** 0.1 to 86,400 Seconds (1-day)

Digital Inputs

- **Number of Inputs:** 2
- **Type:** Optically-Isolated
- **Voltage Range:** 4-26VDC X-401-I: 4-26VDC
- **Current:** 950uA @ 4V, 8.5mA @ 26V
- **Minimum Hold Time:** 20ms
- **Input Functions:** Monitor State, Control Relays, Control Remote Relays, Scalable Counter, On Timer, Total On Timer, Frequency
- **Maximum Count:** 24-bit
- **Max Count Rate:** 200 Hz (Dependent on Configuration)
- **Edge Trigger:** Rising, Falling or Both

Real-Time Clock

- Manual or NTP(Network Time Protocol) setup
- **NTP Sync Period:** Once, Daily, Weekly, On Power-up
- Auto Daylight Savings Adjustment
- Battery (capacitor) Power Backup

Remote Security Gate Control

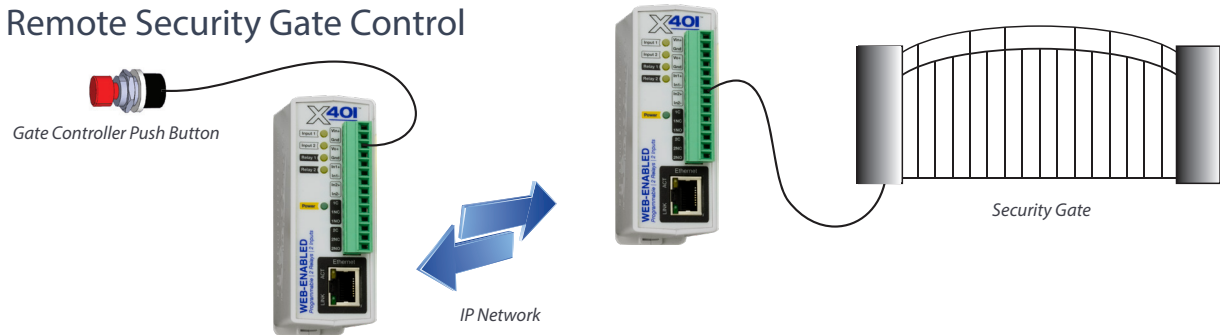

Capacitor Power Backup

- **Backup Functions:** Retain Real-Time Clock, 1 Register, 2 Counters, 2 Relay States
- **Backup Duration:** 2 week minimum

Network

- **Type:** 10/100 Base-T Ethernet Port
- **Setup:** Static or DHCP IP address configuration

Connectors

- **Power/Relays/Inputs:** 14-Position, 3.81mm, Removable
- **Network:** 8-pin RJ-45

LED Indicators

- **Number of LEDs:** 7
 - Power on
 - Relay coil energized 1-2
 - Digital inputs 1-2
 - Network linked
 - Network activity

Physical

- **Operating Temperature:** -40°F to 150°F (-40°C to 65.5°C)
- **Size:**
 - 1.41in (35.7mm) wide
 - 3.88in (98.5mm) tall
 - 3.1in (78mm) deep (not including connector)
- **Weight:** 5 oz (142 grams)
- **Enclosure Material:** Lexan 940 Polycarbonate Plastic
- **Enclosure Flame Rating:** UL94 V0

Additional Applications

- ✓ Traffic Warning Light Controller
- ✓ Electric Door Lock Control
- ✓ Timed Control of Electrical Outlets
- ✓ Vacant Home/Building Monitor
- ✓ Event Counter
- ✓ Extend I/O From a PLC to Another Building
- ✓ More...

Protocols

- HTTP, HTTPS, SSL, XML, Modbus TCP/IP, SNMP, SMTP, Remote Services

Logging

- **Log File Size:** 3,072-Kbyte (up to 50,688 logs)
- **Storage:** Nonvolatile Flash
- **Buffer Architecture:** Circular Buffer
- Log data can be periodically stored on a computer via FTP or email

Advanced Features

- Task Builder
- BASIC interpreter
- Remote services

Password Settings

- **Password Length:** 6-18 Characters

Electromagnetic Compliance

- IEC CISPR 22, CISPR 24
- EU EN55024, EN55022
- X-401-I: FCC 47CFR15 (Class B)
- X-401-E: FCC 47CFR15 (Class A)

Product Safety Compliance

- IEC 61010-1



PRODUCT OVERVIEW



The X-404™ is a powerful web-enabled Modbus controller with advanced logic and modular expansion capabilities.

The X-404 can be programmed either by using its web-page-based “Task Builder” or by writing a BASIC script. The X-404 can seamlessly share I/O on other ControlByWeb devices over the Ethernet network.

Modbus/RS485 Sensors

Monitor RS485 Modbus sensors, and use the X-404's built-in firmware to view and edit modbus/RS485 registers.

Temp/Humidity Sensors

Use the X-404's 1-Wire Bus to monitor up to 16 temperature/humidity sensors.

Remote I/O (Ethernet Connection Only)

The X-404 can also seamlessly communicate and share I/O with any other 400-Series modules (X-410, X-418, etc.) through the TCP/IP network. This remote I/O can be used by the X-404 for any function and works the same as if the I/O was directly connected to the X-404.

Built-in Web Server

Users can operate the X-404 using a web browser, the CBW Mobile app, or custom applications written for a computer, PLC, or other automation controller. No gateways, cloud servers, or external services are required.

Cloud Server (Optional)

The X-404 can, however, be used with our cloud service if desired which simplifies network setup. The X-404 supports standard HTTP requests or encrypted HTTPS requests.

Control/Logic Task Builder

Easily program up to 50 Scheduled task, 50 Conditional tasks, 20 Automatic Reboot tasks, and 20 Override Schedules.

Logic is setup and executed locally on the device, not on the cloud!

Features:

- Connect up to 32 modbus devices/sensors
- 1-Wire Bus for up to 16 sensors (temperature, humidity, etc.)
- Monitor,log, and control up to 32 remote modules, or up to 100 I/O
- User Permissions: Admin, Manager, User
- Tasks
 - 50 Scheduled
 - 50 Conditional
 - 20 Override Schedules
- Send email alerts based on user-defined conditions (supports encrypted email servers, such as Gmail)
- Real-Time Clock with NTP server synchronization
- Automatic daylight savings and leap year adjustment
- No software required
- Customizable web-based Control Page
- BASIC script support for advanced flexibility
- Configurable logging
- Graphing (logged data)
- HTTPS/TLS encrypted
- Static or DHCP IP address configuration
- Modbus, SNMP, Remote Service, IP Filtering
- Field updatable
- Rugged DIN-Rail/wall-mountable enclosure

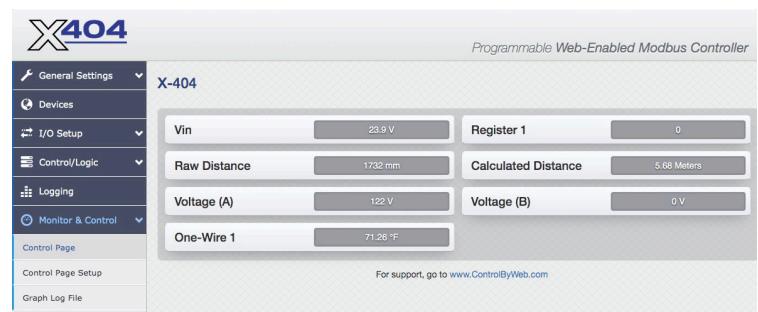

Web-Based Control Page Example

APPLICATIONS & SPECS

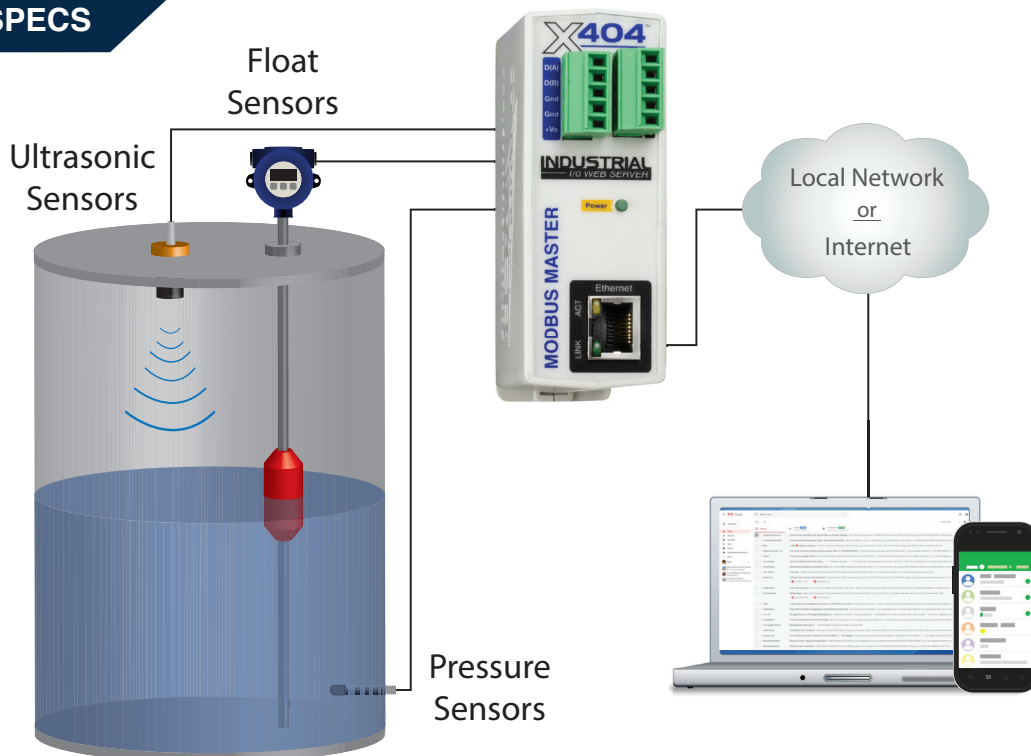

Models:

- X-404-I

Power Requirements

- Voltage: 9-28 VDC
- Max Current: No Modbus Sensors: 134mA
- X-404 + 1.7A for modbus sensors: 1.834A (See users manual for more information)

RS-485 Connector

- Sensors Supported: Up to 32
- Connector: 5-position, removable terminal strip, 3.81 mm spacing
- Communication: RS-485

Temperature Sensors

- Maximum Number of Sensors: 16
- Type: Dallas Semiconductor DS18B20 digital 1-Wire thermometer
- Temperature Range: -67°F to 257°F (-55°C to +125°C)
- Accuracy: ±0.5°C (from -10°C to +85°C)
- Sensor Functions: Monitor Temperature, Log Temperature, Email Alerts, SNMP Traps
- Humidity Type: Xytronix Model X-DTHS-P sensor
- Humidity Range: 0-100% RH
- Accuracy: ±2%
- Max Cable Length: 600 feet (180m) maximum combined cable length

Real-Time Clock

- Manual or NTP(Network Time Protocol) setup
- NTP Sync Period: Once, Daily, Weekly, On Power-up
- Auto Daylight Savings Adjustment
- Battery (capacitor) Power Backup

Capacitor Power Backup

- Backup Functions: Retain Real-Time Clock, 1 Register, 2 Counters, 64 relay states (remote modules only)
- Backup Duration: 2 week minimum

Nonvolatile Memory

- Industrial grade eMMC NANDrive, single level cell (SLC)
- All user settings are stored in nonvolatile memory. Settings will not be lost when power is disconnected.

Network

- Type: 10/100 Base-T Ethernet Port
- Setup: Static or DHCP IP address configuration

Connectors

- Modbus Bus: 5-Position, 3.81mm terminal spacing, Removable. For 16-28 AWG wire.
- Power and 1-Wire Bus: 5-Position, 3.81mm, Removable
- Network: 8-pin RJ-45

LED Indicators

- Number of LEDs: 3
 - Power on
 - Network linked
 - Network activity

Physical

- Operating Temperature: -40°F to 150°F (-40°C to 65.5°C)
- Size:
 - 1.41in (35.7mm) wide
 - 3.88in (98.5mm) tall
 - 3.1in (78mm) deep (not including connector)
- Weight: 5 oz (142 g)
- Enclosure Material: Lexan 940 Polycarbonate Plastic
- Enclosure Flame Rating: UL94 V0

Protocols

- HTTP, HTTPS, SSL, XML, Modbus TCP/IP, Modbus RTU, SNMP V1,2C,V3, SMTP

Logging

- Log File Size: 3,072-Kbyte (up to 50,688 logs)
- Storage: Nonvolatile Flash
- Buffer Architecture: Circular Buffer (Log data can be periodically read and stored on a computer)

Advanced Features

- Task Builder
- BASIC interpreter (up to 4-Kbytes script file size)
- Remote services

Password Settings

- Password protection on setup page: Yes
- Password protection on control page: Optional
- Password Encoding: Base 64
- Max Password Length: 6-18 Characters

Electromagnetic Compliance

- IEC CISPR 22, CISPR 24
- EU EN55024, EN55022
- X-404-I: FCC 47CFR15 (Class B)

Product Safety Compliance

- IEC 61010-1



PRODUCT OVERVIEW

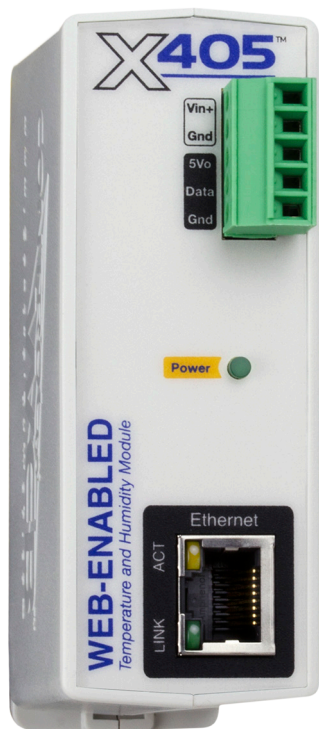

The X-405™ is a fully-featured, web-enabled temperature and humidity module that targets industrial applications.

Sensor values can be monitored over any TCP/IP network including private networks, IP-based industrial control networks, and the Internet. Users can operate the X-405 using a web browser, the CBW Mobile app, or custom applications written for a computer, PLC, or other automation controller.

The X-405's built-in interface allows you to create custom "Tasks" for simple and advanced control logic.

Create tasks based on time, or sensor status. The X-405 also has a built-in BASIC interpreter for custom applications not achievable through the Task Builder system.

Other features are also included such as, email notification, and logging. The X-405 can control and monitor up to 32 remote devices, graph logged data, FTP logged data, email logged data, send encrypted emails, and monitor its power supply voltage.

The X-405 supports a number of Ethernet protocols including: HTTP/HTTPS, Modbus/TCP, SNMP V1,V2 & V3, NTP, SMTP(Encrypted), and FTP/FTPS. The status of the device can be retrieved in human readable formats XML and JSON.

The X-405 supports TLS V1.2 encryption as well as cloud integration(not required) for easier configuration and access. Specifically the X-405 supports HTTPS connections, can send encrypted emails, can communicate with remote devices using TLS, and send logged data to FTP servers over an encrypted connection.

In addition, the X-405 can be configured to automatically connect to ControlByWeb.cloud, ControlByWeb's cloud service. This feature is not required, but does simplify the configuration process and internet access to an X-405 installed behind a network router by eliminating manual configuration of the device and port forwarding setup on routers.

Features:

- 1-Wire Bus for up to 16 sensors (temperature, humidity, etc.)
- Monitor,log, and control up to 32 remote modules, or up to 100 I/O
- User Permissions: Admin, Manager, User
- Tasks
 - 50 Scheduled
 - 50 Conditional
 - 20 Override Schedules
- Send email alerts based on user-defined conditions (supports encrypted email servers, such as Gmail)
- Real-Time Clock with NTP server synchronization
- Automatic daylight savings and leap year adjustment
- No software required
- Customizable web-based Control Page
- BASIC script support for advanced flexibility
- Configurable logging
- Graphing (logged data)
- HTTPS/TLS encrypted
- Static or DHCP IP address configuration
- Modbus, SNMP, Remote Service, IP Filtering
- Field updatable
- Rugged DIN-Rail/wall-mountable enclosure



Example Control Page

APPLICATIONS & SPECS

Greenhouse Temperature & Humidity Monitoring

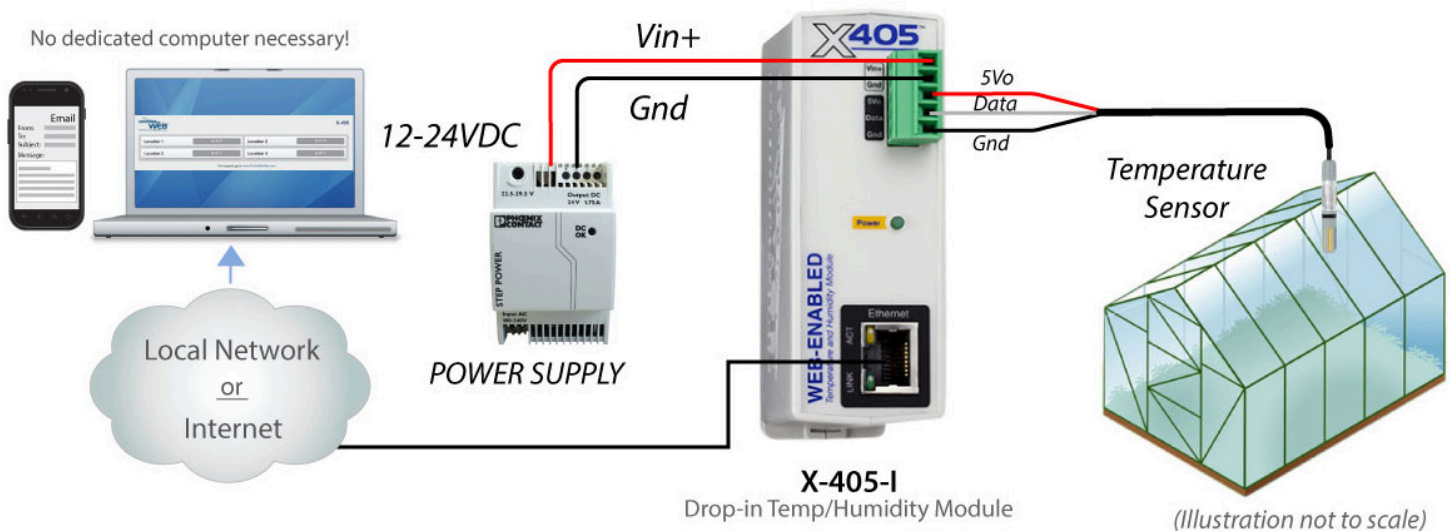

Power Requirements

- **Voltage:**
 - X-405-I: 9-28 VDC
 - X-405-E: POE and/or 9-28VDC
- **Max Current:** 240mA

Temperature Sensors

- **Maximum Number of Sensors:** 16
- **Type:** Dallas Semiconductor DS18B20
- **Temperature Range:** -67°F to 257°F (-55°C to +125°C)
- **Accuracy:** ±0.5°C (from -10°C to +85°C)
- **Sensor Functions:** Monitor Temperature, Log Temperature, Email Alerts, SNMP Traps
- **Humidity Type:** Xytronix Model X-DTHS-P sensor
- **Humidity Range:** 0-100% RH
- **Accuracy:** ±2%
- **Max Cable Length:** 600 feet (180m) maximum combined cable length

Real-Time Clock

- Manual or NTP(Network Time Protocol) setup
- **NTP Sync Period:** Once, Daily, Weekly, On Power-up
- Auto Daylight Savings Adjustment

Capacitor Power Backup

- **Backup Functions:** Retain Real-Time Clock, External Variables, Relay State, and Counters
- **Backup Duration:** 3 days minimum

Network

- **Type:** 10/100 Base-T Ethernet Port
- **Setup:** Static IP address assignment. TCP port selectable

Connectors

- **Power/Input/Relays:** 14-Position, 3.81mm, Removable
- **Network:** 8-pin RJ-45

LED Indicators

- **Number of LEDs:** 3
 - Power on
 - Network linked
 - Network activity

Physical

- **Operating Temperature:** -40°F to 150°F (-40°C to 65.5°C)
- **Size:**
 - 1.41in (35.7mm) wide
 - 3.88in (98.5mm) tall
 - 3.1in (78mm) deep (not including connector)
- **Weight:** 5 oz (142 grams)
- **Enclosure Material:** Lexan 940 Polycarbonate Plastic
- **Enclosure Flame Rating:** UL94 V0

Protocols

- HTTP, HTTPS, SSL, XML, Modbus TCP/IP, SNMP, SMTP, Remote Services

Logging

- **Log File Size:** 512K (up to 8,448 logs)
- **Storage:** Nonvolatile Flash
- **Buffer Architecture:** Circular Buffer
- *Log data can be periodically read and stored on a computer*

Advanced Features

- Task Builder
- BASIC interpreter
- Remote services

Password Settings

- **Password protection on setup page:** Yes
- **Password protection on control page:** Optional
- **Password Encoding:** Base 64
- **Max Password Length:** 18 Characters

Electromagnetic Compliance

- IEC CISPR 22, CISPR 24
- EU EN55024, EN55022
- X-405-I: FCC 47CFR15 (Class B)
- X-405-E: FCC 47CFR15 (Class A)

Product Safety Compliance

- IEC 61010-1



PRODUCT OVERVIEW

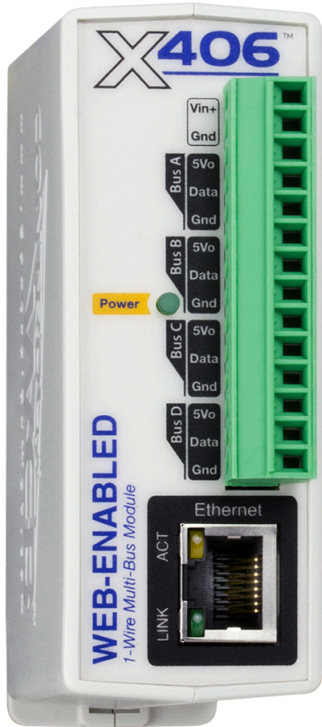

The X-406™ is a fully-featured, web-enabled temperature and humidity module with four independent 1-Wire Buses that allow for monitoring up to 16 temp/humidity sensor per bus, for a total of up to 64 sensors.

The X-406 is ideal for applications where many sensors are required or when you need to run long cable runs per 1-Wire Bus. Up to 600ft total cable length per bus.

Sensor values can be monitored over any TCP/IP network including private networks, IP-based industrial control networks, and the Internet. Users can operate the X-406 using a web browser, the CBW Mobile app, or custom applications written for a computer, PLC, or other automation controller.

The X-406's built-in interface allows you to create custom "Tasks" for simple and advanced control logic.

Create tasks based on time, or sensor status. The X-406 also has a built-in BASIC interpreter for custom applications not achievable through the Task Builder system.

Other features are also included such as, email notification, and logging. The X-406 can control and monitor up to 32 remote devices, graph logged data, FTP logged data, email logged data, send encrypted emails, and monitor its power supply voltage.

The X-406 supports a number of Ethernet protocols including: HTTP/HTTPS, Modbus/TCP, SNMP V1,V2 & V3, NTP, SMTP(Encrypted), and FTP/FTPS. The status of the device can be retrieved in human readable formats XML and JSON.

The X-406 supports TLS V1.2 encryption as well as cloud integration (not required) for easier configuration and access. Specifically the X-406 supports HTTPS connections, can send encrypted emails, can communicate with remote devices using TLS, and send logged data to FTP servers over an encrypted connection.

In addition, the X-406 can be configured to automatically connect to ControlByWeb.cloud, ControlByWeb's cloud service. This feature is not required, but does simplify the configuration process and internet access to an X-406 installed behind a network router by eliminating manual configuration of the device and port forwarding setup on routers.

Features:

- Four independent 1-Wire Buses
- Connect up to 16 sensors per 1-Wire Bus for monitoring up to 64 sensors (temperature, humidity, etc.)
- Monitor, log, and control 32 remote modules, or up to 100 I/O
- User Permissions: Admin, Manager, User
- Tasks
 - 50 Scheduled
 - 50 Conditional
 - 20 Override Schedules
- Send email alerts based on user-defined conditions (supports encrypted email servers, such as Gmail)
- Real-Time Clock with NTP server synchronization
- Automatic daylight savings and leap year adjustment
- No software required
- Customizable web-based Control Page
- BASIC script support for advanced flexibility
- Configurable logging
- Graphing (logged data)
- HTTPS/TLS encrypted
- Static or DHCP IP address configuration
- Modbus, SNMP, Remote Service, IP Filtering
- Field updatable
- Removable 14-Terminal connector for easy installation
- Rugged DIN-Rail/wall-mountable enclosure

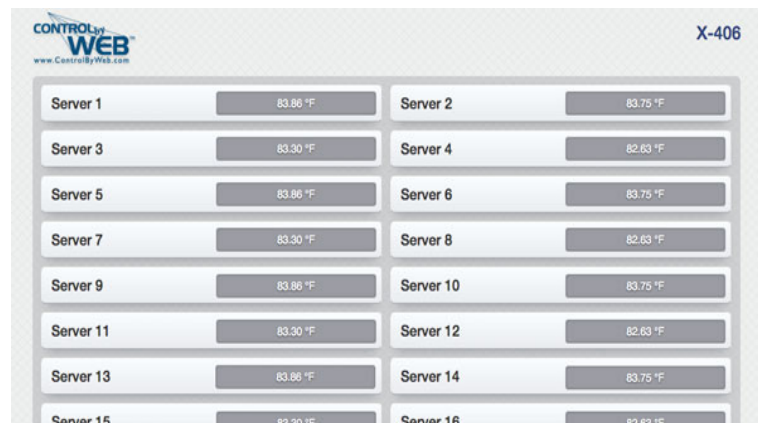

Example Control Page

APPLICATIONS & SPECS

Server Room Temperature & Humidity Monitoring

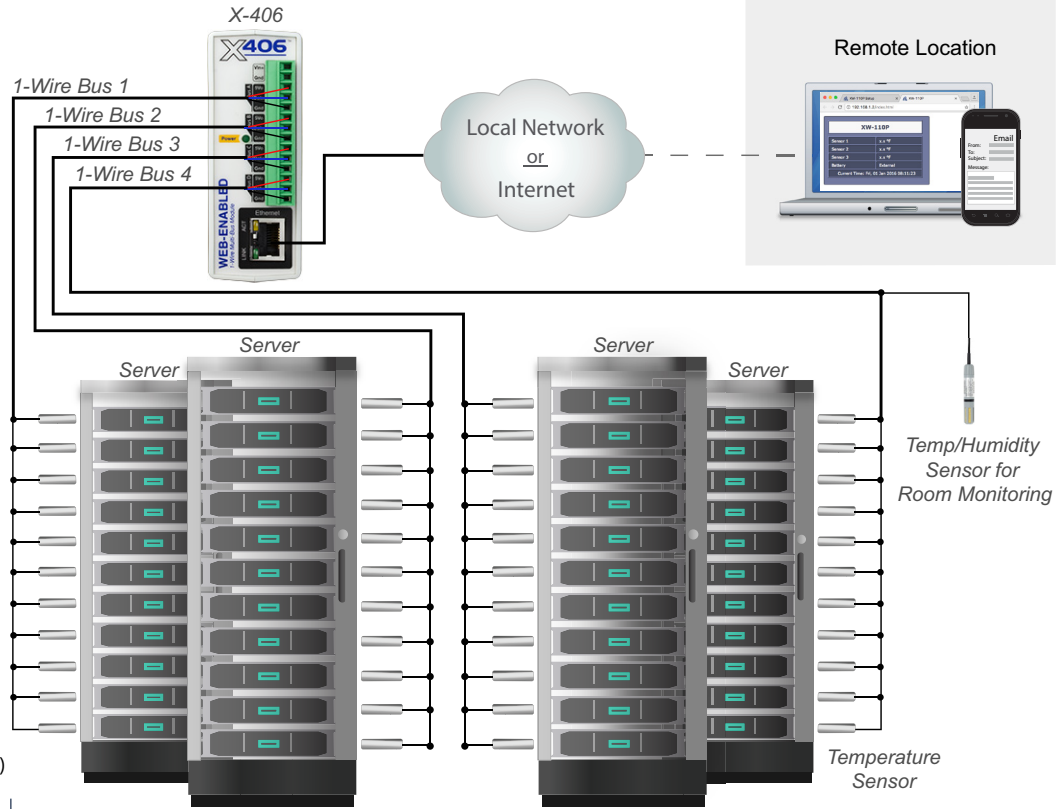

Power Requirements

- **Voltage:**
 - X-406-I: 9-28 VDC
 - X-406-E: POE and/or 9-28VDC
- **Max Current:** 240mA

Temperature Sensors

- **Maximum Number of Sensors:** 64
- **Type:** Dallas Semiconductor DS18B20
- **Temperature Range:** -67°F to 257°F (-55°C to +125°C)
- **Accuracy:** ±0.5°C (from -10°C to +85°C)
- **Sensor Functions:** Monitor Temperature, Log Temperature, Email Alerts, SNMP Traps
- **Humidity Type:** Xytronix Model X-DTHS-P sensor
- **Humidity Range:** 0-100% RH
- **Accuracy:** ±2%
- **Max Cable Length:** 600 feet (180m) maximum combined cable length

Real-Time Clock

- Manual or NTP(Network Time Protocol) setup
- **NTP Sync Period:** Once, Daily, Weekly, On Power-up
- Auto Daylight Savings Adjustment

Capacitor Power Backup

- **Backup Functions:** Retain Real-Time Clock, External Variables, Relay State, and Counters
- **Backup Duration:** 3 days minimum

Network

- **Type:** 10/100 Base-T Ethernet Port
- **Setup:** Static IP address assignment. TCP port selectable

Connectors

- **Power/Input/Relays:** 14-Position, 3.81mm, Removable
- **Network:** 8-pin RJ-45

LED Indicators

- **Number of LEDs:** 3
 - Power on
 - Network linked
 - Network activity

Physical

- **Operating Temperature:** -40°F to 150°F (-40°C to 65.5°C)
- **Size:**
 - 1.41in (35.7mm) wide
 - 3.88in (98.5mm) tall
 - 3.1in (78mm) deep (not including connector)
- **Weight:** 5 oz (142 grams)
- **Enclosure Material:** Lexan 940 Polycarbonate Plastic
- **Enclosure Flame Rating:** UL94 V0

Protocols

- HTTP, HTTPS, SSL, XML, Modbus TCP/IP, SNMP, SMTP, Remote Services

Logging

- **Log File Size:** 512K (up to 8,448 logs)
- **Storage:** Nonvolatile Flash
- **Buffer Architecture:** Circular Buffer
- *Log data can be periodically read and stored on a computer*

Advanced Features

- Task Builder
- BASIC interpreter
- Remote services

Password Settings

- **Password protection on setup page:** Yes
- **Password protection on control page:** Optional
- **Password Encoding:** Base 64
- **Max Password Length:** 18 Characters

Electromagnetic Compliance

- IEC CISPR 22, CISPR 24
- EU EN55024, EN55022
- X-406-I: FCC 47CFR15 (Class B)
- X-406-E: FCC 47CFR15 (Class A)

Product Safety Compliance

- IEC 61010-1



PRODUCT OVERVIEW

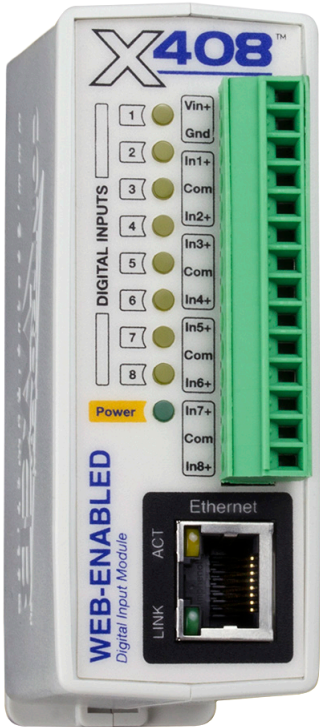

The X-408™ is a fully-featured, web-enabled digital input monitoring device.

It is ideal for applications that require discrete input monitoring over an IP network.

Digital inputs can be connected to: Buttons/Switches, water sensors, float switches, security sensors, limit switches, counters, flow sensors, and more.

The values from the digital inputs can be monitored over any TCP/IP network including private networks, IP-based industrial control networks, and the Internet.

Users can operate the X-408 using a web browser, the CBW Mobile app, or custom applications written for a computer, PLC, or other automation controller.

Frequency/Counter Inputs

Configure an input for discrete, counter, or frequency measurement.

Peer-to-Peer Communication

Share real-time input states with other ControlByWeb devices.

Email/Text Alerts

Customizable email/text alerts based on input states.

Logging/ Graphing

Log and graph digital input states over time.

I/O Mirroring

Mirror the state of the inputs' to relays on remote devices.

Communication Protocols

The X-408 supports a number of Ethernet protocols including: HTTP/HTTPS, Modbus TCP/IP, SNMP V1,V2 & V3, NTP, SMTP(Encrypted), and FTP/FTPS. The status of the device can be retrieved in human readable formats XML and JSON.

The X-408 supports TLS V1.2 encryption as well as cloud integration (optional) for easier configuration and access. Specifically the X-408 supports HTTPS connections, can send encrypted emails, can communicate with remote devices using TLS, and send logged data to FTP servers over an encrypted connection.

INCLUDES 400-SERIES ADVANCED FEATURES

The X-408 also has other robust features found in other 400-Series products: Task Builder, encryption, intuitive user interface, much more.

Features:

- Eight optically-isolated digital inputs
- Each input can be configured as:
 - Discrete On/Off
 - Counters
 - Frequency measurements
- Monitor, log, and control 32 remote modules, or up to 100 I/O
- User Permissions: Admin, Manager, User
- Tasks
 - 50 Scheduled
 - 50 Conditional
 - 20 Override Schedules
- Send email alerts based on user-defined conditions (supports encrypted email servers, such as Gmail)
- Real-Time Clock with NTP server synchronization
- Automatic daylight savings and leap year adjustment
- No software required
- Customizable web-based Control Page
- BASIC script support for advanced flexibility
- Configurable logging
- Graphing (logged data)
- HTTPS/TLS encrypted
- Static or DHCP IP address configuration
- Modbus, SNMP, Remote Service, IP Filtering
- Field updatable
- Removable 14-Terminal connector for easy installation
- Rugged DIN-Rail/wall-mountable enclosure

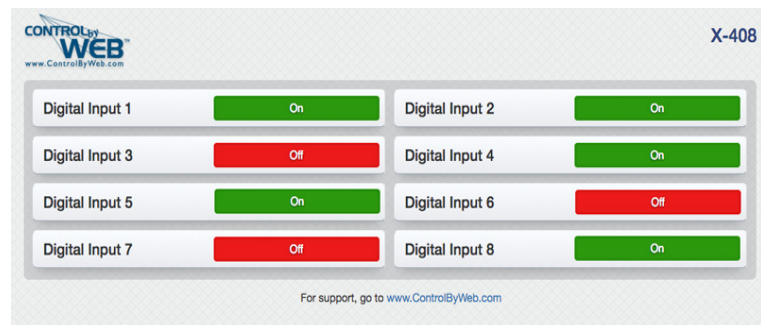

Example Control Page

APPLICATIONS & SPECS

I/O Mirroring using the X-408 and other ControlByWeb Products

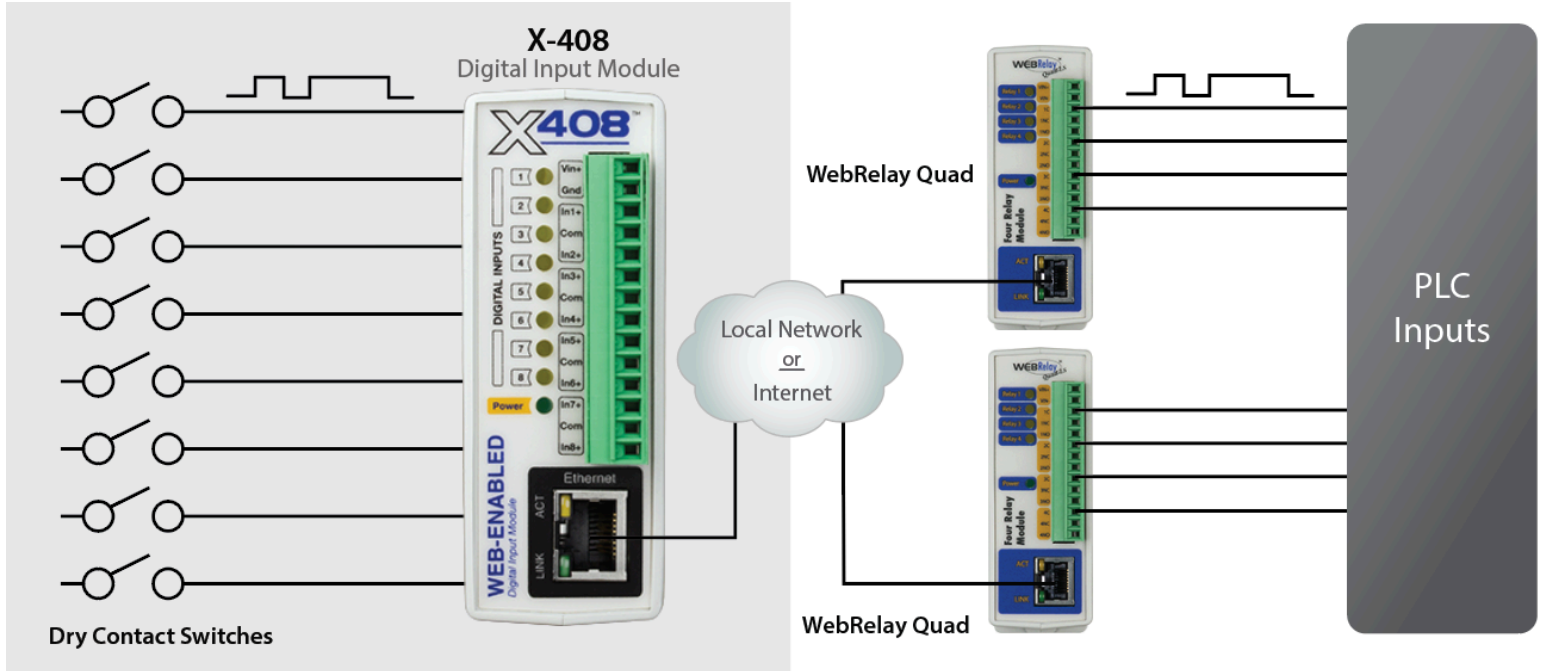

Power Requirements

- **Voltage:**
 - X-408-I: 9-28 VDC
 - X-408-E: POE and/or 9-28VDC
- **Max Current:** 240mA

Real-Time Clock

- Manual or NTP(Network Time Protocol) setup
- **NTP Sync Period:** Once, Daily, Weekly, On Power-up
- Auto Daylight Savings Adjustment

Digital Inputs

- **Number of Inputs:** 8
- **Type:** Optically-Isolated
- **Voltage Range:** 4-26 VDC
- **Current:** 950uA @ 4V, 8.5mA @ 26V
- **Minimum Hold Time:** 20mS
- **Input Functions:** Monitor State, Control Relays, Control Remote Relays, Scalable Counter, On Timer, Total On Timer, Frequency
- **Maximum Count:** 24-bit
- **Max Count Rate:** 20Hz Max (Dependent on Configuration)
- **Edge Trigger:** Rising, Falling or Both

Capacitor Power Backup

- **Backup Functions:** Retain Real-Time Clock, External Variables, Relay State, and Counters
- **Backup Duration:** 3 days minimum

Network

- **Type:** 10/100 Base-T Ethernet Port
- **Setup:** Static IP address assignment. TCP port selectable

Connectors

- **Power/Input/Relays:** 14-Position, 3.81mm, Removable
- **Network:** 8-pin RJ-45

LED Indicators

- **Number of LEDs:** 3
 - Power on
 - Network linked
 - Network activity

Physical

- **Operating Temperature:** -40°F to 150°F (-40°C to 65.5°C)
- **Size:**
 - 1.41in (35.7mm) wide
 - 3.88in (98.5mm) tall
 - 3.1in (78mm) deep (not including connector)
- **Weight:** 5 oz (142 grams)
- **Enclosure Material:** Lexan 940 Polycarbonate Plastic
- **Enclosure Flame Rating:** UL94 V0

Protocols

- HTTP, HTTPS, SSL, XML, Modbus TCP/IP, SNMP, SMTP, Remote Services

Logging

- **Log File Size:** 512K (up to 8,448 logs)
- **Storage:** Nonvolatile Flash
- **Buffer Architecture:** Circular Buffer
- *Log data can be periodically read and stored on a computer*

Advanced Features

- Task Builder
- BASIC interpreter
- Remote services

Password Settings

- **Password protection on setup page:** Yes
- **Password protection on control page:** Optional
- **Password Encoding:** Base 64
- **Max Password Length:** 18 Characters

Electromagnetic Compliance

- IEC CISPR 22, CISPR 24
- EU EN55024, EN55022
- X-408-I: FCC 47CFR15 (Class B)
- X-408-E: FCC 47CFR15 (Class A)

Product Safety Compliance

- IEC 61010-1



PRODUCT OVERVIEW

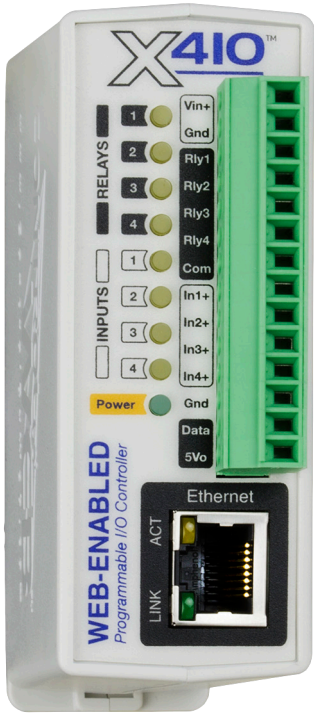

The X-410™ is a multifunction web-enabled module for control and monitoring. The X-410 has four internal relays, four digital inputs, four pulse counters, 16 general purpose timers, 16 general purpose registers and a 1-Wire® bus. The 1-Wire bus supports up to 16 sensors for monitoring temperature, humidity and more.

It can be controlled and/or monitored over any TCP/IP network including private networks, IP-based industrial control networks, and the Internet. Users can operate the X-410 using a web browser, the CBW Mobile app, or custom applications written for a computer, PLC, or other automation controller.

The X-410's built-in interface allows you to create custom "Tasks" for simple and advanced control logic.

Create tasks based on time, input or outputs' status, or the responsiveness of remote devices. The X-410 also has a built-in BASIC interpreter for custom applications not achievable through the Task Builder system.

Other features are also included such as, email notification, event scheduling, and logging. The X-410 can control and monitor up to 32 remote devices, graph logged data, FTP logged data, email logged data, send encrypted emails, and monitor its power supply voltage.

The X-410 supports a number of Ethernet protocols including: HTTP/HTTPS, Modbus/TCP, SNMP V1,V2 & V3, NTP, SMTP(Encrypted), and FTP/FTPS. The status of the device can be retrieved in human readable formats XML and JSON.

The X-410 supports TLS V1.2 encryption as well as cloud integration(not required) for easier configuration and access. Specifically the X-410 supports HTTPS connections, can send encrypted emails, can communicate with remote devices using TLS, and send logged data to FTP servers over an encrypted connection.

In addition, the X-410 can be configured to automatically connect to ControlByWeb.cloud, ControlByWeb's cloud service. This feature is not required, but does simplify the configuration process and internet access to an X-410 installed behind a network router by eliminating manual configuration of the device and port forwarding setup on routers.

Features:

- Four electro-mechanical relays (shared common) independently controlled
- Four digital inputs (shared ground)
- 1-Wire Bus for up to 16 sensors (temperature, humidity, ultrasonic sensors, etc.)
- Control, monitor, and log 32 remote modules, or up to 100 I/O
- User Permissions: Admin, Manager, User
- Tasks
 - 50 Scheduled
 - 50 Conditional
 - 16 Automatic Reboot
 - 20 Override Schedules
- Send email alerts based on user-defined conditions (supports encrypted email servers, such as Gmail)
- Real-Time Clock with NTP server synchronization
- Automatic daylight savings and leap year adjustment
- Highly configurable - Almost any combination of input/relay control possible
- No software required
- Customizable web-based Control Page
- BASIC script support for advanced flexibility
- Configurable logging
- Graphing (logged data)
- HTTPS/TLS encrypted
- Static or DHCP IP address configuration
- Modbus, SNMP, Remote Service, IP Filtering
- Field updatable
- Removable 14-Terminal connector for easy installation
- Rugged DIN-Rail/wall-mountable enclosure
- 5-Year Warranty

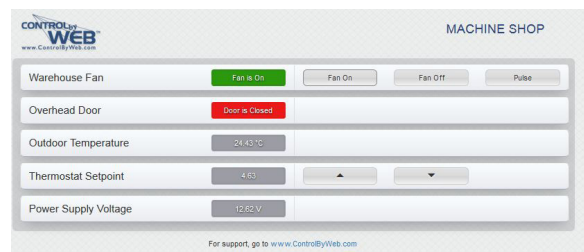

Example Control Page

APPLICATIONS & SPECS

Server Room Control & Monitoring

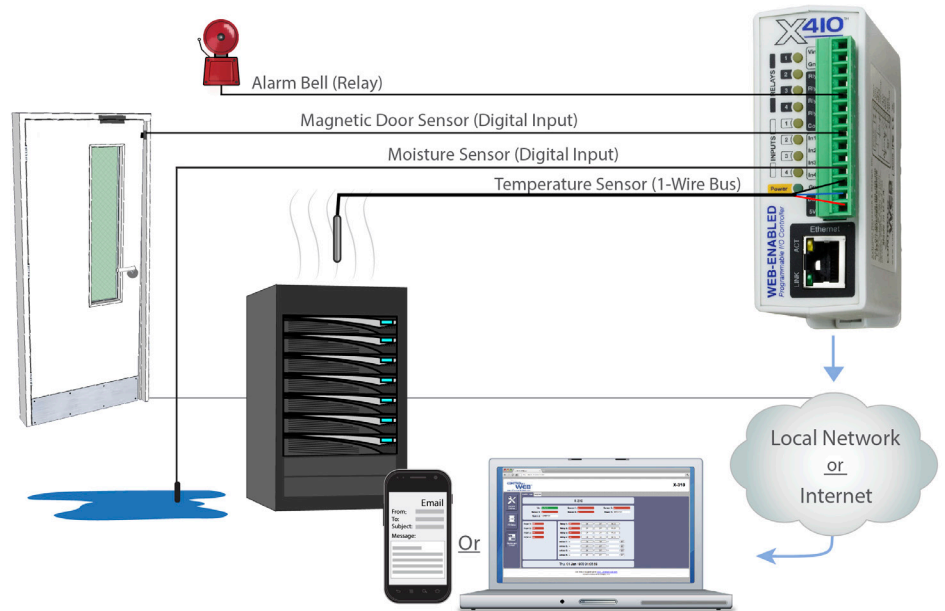

Power Requirements

- **Voltage:**
 - X-410-I: 9-28 VDC
 - X-410-E: POE and/or 9-28VDC
- **Max Current:** 240mA

Relays

- **Number of Relays:** 4
- **Max Voltage:** 28VAC, 24VDC
- **Max Current:** 1A
- **Contact Type:** SPST (Form 1A) - All relays have a shared common
- **Load Type:** General Purpose
- **Contact Resistance:** 1 milliohm max
- **Contact Material:** AgNi
- **Electrical Life:** 100K operations (Min)
- **Mechanical Life:** 5M cycles (Min)
- **Environmental Rating:** Over voltage Category II, Pollution Degree 2
- **Relay Modes:** ON/OFF or Pulsed
- **Pulse Timer Duration:** 0.1 to 86,400 Seconds (1-day)

Digital Inputs

- **Number of Inputs:** 4
- **Type:** Non-Isolated
- **Voltage Range:** 4-26 VDC
- **Current:** 950uA @ 4V, 8.5mA @ 26V
- **Minimum Hold Time:** 20mS
- **Input Functions:** Monitor State, Control Relays, Control Remote Relays, Scalable Counter, On Timer, Total On Timer, Frequency
- **Maximum Count:** 24-bit
- **Max Count Rate:** 20Hz Max (Dependent on Configuration)
- **Edge Trigger:** Rising, Falling or Both

Temperature Sensors

- **Maximum Number of Sensors:** 16
- **Type:** Dallas Semiconductor DS18B20
- **Temperature Range:** -67°F to 257°F (-55°C to +125°C)
- **Accuracy:** ±0.5°C (from -10°C to +85°C)
- **Sensor Functions:** Monitor Temperature, Log Temperature, Email Alerts, SNMP Traps
- **Humidity Type:** Xytronix Model X-DTHS-P sensor

- **Humidity Range:** 0-100% RH
- **Accuracy:** ±2%
- **Max Cable Length:** 600 feet (180m) maximum combined cable length

Real-Time Clock

- Manual or NTP(Network Time Protocol) setup
- **NTP Sync Period:** Once, Daily, Weekly, On Power-up
- Auto Daylight Savings Adjustment

Capacitor Power Backup

- **Backup Functions:** Retain Real-Time Clock, External Variables, Relay State, and Counters
- **Backup Duration:** 3 days minimum

Network

- **Type:** 10/100 Base-T Ethernet Port
- **Setup:** Static IP address assignment. TCP port selectable

Connectors

- **Power/Input/Relays:** 14-Position, 3.81mm, Removable
- **Network:** 8-pin RJ-45

LED Indicators

- **Number of LEDs:** 11
 - Power on
 - Relay coil energized 1-4
 - Digital Input 1-4
 - Network linked
 - Network activity

Physical

- **Operating Temperature:** -40°F to 150°F (-40°C to 65.5°C)
- **Size:**
 - 1.41in (35.7mm) wide
 - 3.88in (98.5mm) tall
 - 3.1in (78mm) deep (not including connector)

- **Weight:** 5 oz (142 grams)
- **Enclosure Material:** Lexan 940 Polycarbonate Plastic
- **Enclosure Flame Rating:** UL94 V0

Protocols

- HTTP, HTTPS, SSL, XML, Modbus TCP/IP, SNMP, SMTP, Remote Services

Logging

- **Log File Size:** 512K (up to 8,448 logs)
- **Storage:** Nonvolatile Flash
- **Buffer Architecture:** Circular Buffer
- *Log data can be periodically read and stored on a computer*

Advanced Features

- Task Builder
- BASIC interpreter
- Remote services

Password Settings

- **Password protection on setup page:** Yes
- **Password protection on control page:** Optional
- **Password Encoding:** Base 64
- **Max Password Length:** 18 Characters

Electromagnetic Compliance

- IEC CISPR 22, CISPR 24
- EU EN55024, EN55022
- X-410-I: FCC 47CFR15 (Class B)
- X-410-E: FCC 47CFR15 (Class A)

Product Safety Compliance

- IEC 61010-1



PRODUCT OVERVIEW

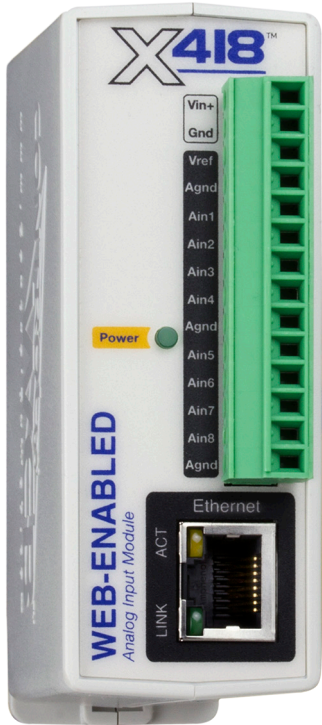

The X-418™ is a web-enabled, industrial analog input module. It features an eight-channel, 16-bit, analog data acquisition system. Each channel is configurable for single-ended or differential inputs. Programmable voltage ranges include; $\pm 1.28V$, $\pm 2.56V$, $\pm 5.12V$ and $\pm 10.24V$.

It can be controlled and/or monitored over any TCP/IP network including private networks, IP-based industrial control networks, and the Internet.

Users can operate the X-418 using a web browser, the CBW Mobile app, or custom applications written for a computer, PLC, or other automation controller. The built-in web server means users can access the X-418 directly as a self-contained, stand-alone unit. No gateways, cloud servers, or external services are required. The X-418 can be used, however, with our ControlByWeb.cloud cloud service if

desired which simplifies network setup.

The X-418's built-in interface allows you to create custom "Tasks" for simple and advanced control logic, without the need for scripting. Easily create tasks based on time or input status. The X-418 also has a built-in BASIC interpreter for more advanced or custom applications not achievable through the Task Builder system.

Other features are also included such as: Email notification (encrypted), event scheduling, logging & graphing (graph logged data, FTP logged data, email logged data), Control and monitor up to 32 remote devices, internal power supply voltage monitor, etc.

The X-418 supports several Ethernet protocols including: HTTP/HTTPS, Modbus/TCP, SNMP V1,V2 & V3, NTP, SMTP(Encrypted), and FTP/FTPS. (The status of the device can be retrieved in human readable formats XML and JSON.)

The X-418 supports TLS V1.2 encryption as well as cloud integration(not required) for easier configuration and access. Specifically the X-418 supports HTTPS connections, can send encrypted emails, can communicate with remote devices using TLS, and send logged data to FTP servers over an encrypted connection.

In addition, the X-418 can be configured to automatically connect to ControlByWeb.cloud, ControlByWeb's cloud service. This feature is not required, but does simplify the configuration process and internet access to an X-418 installed behind a network router by eliminating manual configuration of the device and port forwarding setup on routers. The options to use the X-418 as a stand alone device or through a cloud server makes it very powerful and very flexible.

Features:

- Built-in web server for configuration and remote monitoring (HTTPS supported).
- Eight-channel, programmable, 16-bit, analog data acquisition system.
 - Programmable voltage ranges include; $\pm 1.28V$, $\pm 2.56V$, $\pm 5.12V$, $10.24V$, and $4-20mA$
- Sensor/Input status can control I/O on other ControlByWeb devices.
- Control/Logic Task Builder for custom control with no scripting necessary.
- Configurable logging of all I/O, both local and remote.
- Real-time clock with manual or NTP time sync.
- Send email alerts (up to 8 addresses) based on any sensor or input conditions.
- Send encrypted emails.
- Auxiliary protocols including Modbus/TCP, SNMP V1,V2 & V3, and Remote Services.
- Custom scripts using the built-in BASIC interpreter provide additional flexibility.
- Ethernet auto-negotiation automatically selects speed, duplex mode and works with straight or crossover cables.
- Power Supply: 9 to 28V DC power adapter and/or POE.
- Simple and easy to use.
- 5-year warranty.



Example X-418 Control Page

APPLICATIONS & SPECS

Potentiometer Position Sensor Monitoring

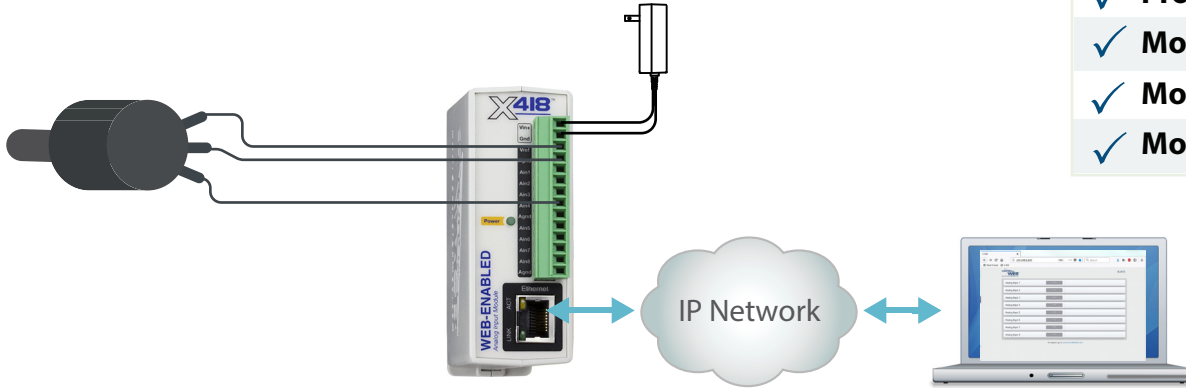

Additional Applications

- ✓ I/O Extender
- ✓ POE weather station
- ✓ Process Controller
- ✓ Monitor fluid level
- ✓ Monitor temperature
- ✓ Monitor water level

Power Requirements

- **Voltage:**
 - X-418-I: 9-28 VDC
 - X-418-E: POE and/or 9-28VDC
- **Max Current:** 152mA

Analog Inputs

- **Number of Inputs:** 8
- **Resolution:** 16-bit, SAR
- **Type:**
 - **Channels 1-4:** Single ended, differential or 4-20mA (0-20mA)
 - **Channels 5-8:** Single ended or differential
 - **Channels 1-8:** Pseudo digital input
- **Input Range (Programmable):** $\pm 1.28V$, $\pm 2.56V$, $\pm 5.12V$, $\pm 10.24V$, $\pm 20.48V$ (differential)
- **Max Input Voltage (Vin):** $-12.5V < V_{in} < +12.5V$
- **Input Impedance (Zin):** $> 500\text{Meg Ohm}$
- **Channel Off Leakage:** $\pm 0.6nA$ (typ)
- **Input Common Mode Rejection:** $> 100dB$
- **Total Unadjusted Error:** -9LSB (min), +9LSB (max)
- **Voltage Reference Drift:** $\pm 5 \text{ ppm}/^\circ\text{C}$
- **Internal 4-20mA input shunt:** 200-ohm, $\pm 0.1\%$, 25ppm (uses $\pm 5.12V$ range)
- **Logging Rate:** 25 Hz
- **Sample Rate:** 50 Hz

Pseudo Digital Inputs

- **Number:** Programmable option, channels 1 to 8
- **Vih (high-level input voltage):** 3.5V
- **Vil (low-level input voltage):** 1.5V
- **Sample Rate:** 50 Hz

Real-Time Clock

- Manual or NTP(Network Time Protocol) setup
- **NTP Sync Period:** Once, Daily, Weekly, On Power-up
- Auto Daylight Savings Adjustment

Capacitor Power Backup

- **Backup Functions:** Retain Real-Time Clock, External Variables, Relay State, and Counters
- **Backup Duration:** 2-weeks min

Network

- **Type:** 10/100 Base-T Ethernet Port
- **Setup:** Static IP address assignment. TCP port selectable

Connectors

- **Power/Input/Relays:** 14-Position, 3.81mm, Removable
- **Network:** 8-pin RJ-45

LED Indicators

- **Number of LEDs:** 3
 - Power on
 - Network linked
 - Network activity

Physical

- **Operating Temperature:** -40°F to 150°F (-40°C to 65.5°C)
- **Size:**
 - 1.41in (35.7mm) wide
 - 3.88in (98.5mm) tall
 - 3.1in (78mm) deep (not including connector)
- **Weight:** 5 oz (142 grams)
- **Enclosure Material:** Lexan 940 Polycarbonate Plastic
- **Enclosure Flame Rating:** UL94 V0

Protocols

- HTTP, HTTPS, SSL, XML, Modbus TCP/IP, SNMP, SMTP, Remote Services

Logging

- **Log File Size:** 3072K (up to 50,688 log entries depending on configuration)
- **Storage:** Nonvolatile Flash
- **Buffer Architecture:** Circular Buffer
- *Log data can be periodically read and stored on a computer*

Advanced Features

- Task Builder
- BASIC interpreter
- Remote services

Password Settings

- **Password protection on setup page:** Yes
- **Password protection on control page:** Optional
- **Password Encoding:** Base 64
- **Max Password Length:** 18 Characters

Electromagnetic Compliance

- IEC CISPR 22, CISPR 24
- EU EN55024, EN55022
- X-418-I: FCC 47CFR15 (Class B)
- X-418-E: FCC 47CFR15 (Class A)

Product Safety Compliance

- IEC 61010-1



PRODUCT OVERVIEW

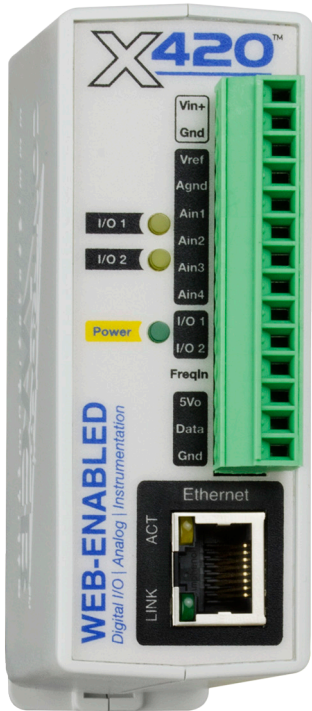

The X-420™ is a multifunction web-enabled industrial control and instrumentation module. The X-420 has four multi-function analog inputs, two digital I/O with programmable pull resistors, two pulse counters, one frequency input, 16 general purpose timers, 16 general purpose registers, and a 1-Wire® bus. The 1-Wire bus supports up to 16 sensors for monitoring temperature, humidity and more. It can be controlled and/or monitored over any TCP/IP network including private networks, IP-based industrial control networks, and the Internet. Users can operate the X-420 using a web browser, the CBW Mobile app, or custom applications written for a computer, PLC, or other automation controller.

The X-420's built-in interface allows you to create custom "Tasks" for simple and

advanced control logic. Easily create tasks based on time, input or outputs' status, or device responsiveness. The X-420 also has a built-in BASIC interpreter for custom applications not achievable through the Task Builder system.

The module is powered by an external wall transformer (9-28 VDC), solar panel, or other DC power source. The model X-420-E is powered over the twisted pair Ethernet cable.

Other features are also included such as, email notification, event scheduling, and logging. The X-420 can control and monitor up to 32 remote devices, graph logged data, FTP logged data, email logged data, send encrypted emails, and monitor its power supply voltage. The X-420 supports a number of Ethernet protocols including HTTP/HTTPS, Modbus/TCP, SNMP V1,V2 & V3, NTP, SMTP(Encrypted), and FTP/FTPS. The status of the device can be retrieved in human readable formats XML and JSON.

The X-420 supports TLS V1.2 encryption as well as cloud integration(not required) for easier configuration and access. Specifically the X-420 supports HTTPS connections, can send encrypted emails, can communicate with remote devices using TLS, and send logged data to FTP servers over an encrypted connection. In addition, the X-420 can be configured to automatically connect to ControlByWeb.cloud, ControlByWeb's cloud service. This feature is not required, but does simplify the configuration process and internet access to an X-420 installed behind a network router by eliminating manual configuration of the device and port forwarding setup on routers.

Features:

- Built-in web server for configuration and remote monitoring (HTTPS supported).
- Four channel, programmable, 16-bit, analog data acquisition system.
- Two 5V digital input/outputs. Use as inputs to monitor wind speed or rainfall etc. Use as outputs to control relays or other devices.
- Two pulse counters.
- Millivolt AC frequency input for use with magnetic or optical wind speed sensors
- 1-Wire port for connecting up to 16 digital sensors for measuring temperature, humidity and more.
- 1-Wire temperature sensors are available in various packaging and accuracy.
- Sensor/Input status can control I/O on other ControlByWeb devices.
- Control/Logic Task Builder for custom control with no scripting necessary.
- Configurable logging of all I/O, both local and remote.
- Real-time clock with manual or NTP time sync.
- Send email alerts (up to 8 email addresses) based on any sensor or input conditions.
- Send encrypted emails.
- Auxiliary protocols including: Modbus/TCP, SNMP V1,V2 & V3, and Remote Services.
- Custom scripts using the built-in BASIC interpreter provide additional flexibility.
- Ethernet auto-negotiation automatically selects speed, duplex mode and works with straight or crossover cables.
- Simple and easy to use.
- Power Supply: 9 to 28VDC and/or POE
- 5-year warranty.

Example Control Page

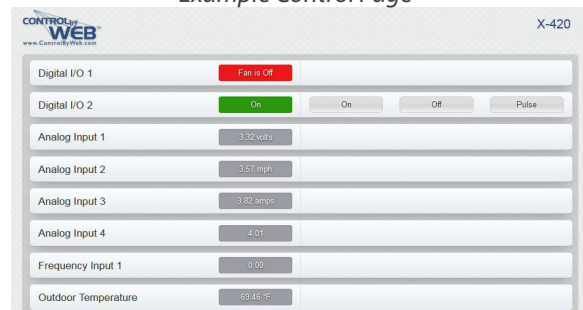

APPLICATIONS & SPECS

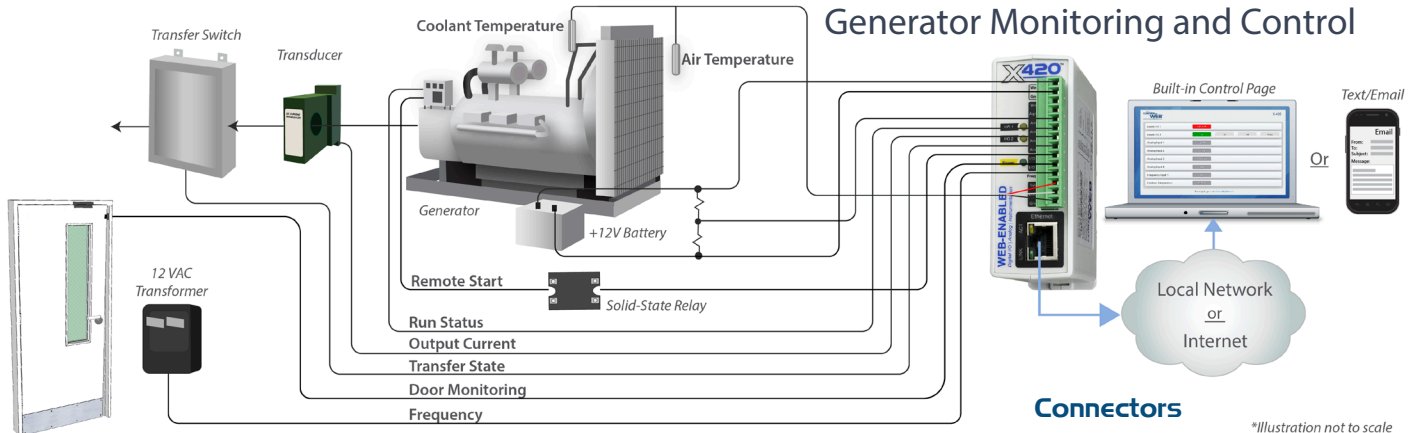

Generator Monitoring and Control

Power Requirements

- Voltage:**
 - X-420-I: 9-28 VDC
 - X-420-E: POE and/or 9-28VDC
- Max Current:** 175mA Max (2-Digital I/O=On, no 1-wire sensors. See users manual for typical values at 25°C)

Output Mode

- Logic output to external controllers 5V high through 49.9 Ohm resistor

Digital Inputs

- Number of Inputs:** 2 (Configurable)
- Type:** Non-Isolated
- Voltage Range:** 0-5VDC
- Current:** Switchable 47K Pullup/Pulldown
- Vin Hi (Min):** 3.5V
- Vin LO (Max):** 1.5V
- Debounce:** 0 to 250mS (configurable)
- Minimum Hold Time:** 1mS
- Number of Counter Inputs:** 0-2 (configurable)
- Max Count Rate:** 200Hz Max
- Input Functions:** Monitor State, Control Digital I/O, Control Remote Relays, Scalable Counter, On Timer, Total On Timer, Frequency
- Edge Trigger:** Rising, Falling or Both

Frequency Input

- Type:** AC coupled, sine or square wave (works with millivolt magnetic wind speed sensors)
- Input Voltage:** +/-12 VDC, 30Vpp AC max
- Hysteresis:** 25mV
- 0-20 kHz input frequency
- Sine or Square Wave
- 1 second average
- Minimum input level:**

Input Frequency	Min Vin
Vin @ 1 Hz	50mVpp
Vin @ 10 Hz	50mVpp
Vin @ 100 Hz	60mVpp
Vin @ 1 kHz	80mVpp
Vin @ 10 kHz	700mVpp
Vin @ 20 kHz	1.7Vpp min

Analog Inputs

- Number of Inputs:** 4
- Resolution:** 16-bit, SAR
- Type:** Single-ended, differential, 4-20mA (0-20mA), or a combination
- Input Range:** $\pm 1.28V, \pm 2.56V, \pm 5.12V, \pm 10.24V$
- Max Input Voltage (Vin):** $-12.5V < V_{in} < +12.5V$
- Input Impedance (Zin):** $> 500\text{Meg Ohm}$
- Channel Off Leakage:** $\pm 0.6nA$ (typ)
- Input Common Mode Rejection:** $> 100\text{dB}$
- Total Unadjusted Error:** -9LSB (min), +9LSB (max)
- Voltage Reference Drift:** $\pm 5\text{ ppm}/^\circ\text{C}$
- Internal 4-20mA input shunt:** 200-ohm, $\pm 0.1\%$, 25ppm (uses $\pm 5.12V$ range)
- Logging Rate:** 25 Hz

Temperature Sensors

- Maximum Number of Sensors:** 16
- Type:** Dallas Semiconductor DS18B20
- Temperature Range:** -67°F to 257°F (-55°C to $+125^\circ\text{C}$)
- Accuracy:** $\pm 0.5^\circ\text{C}$ (from -10°C to $+85^\circ\text{C}$)
- Sensor Functions:** Monitor Temperature, Log Temperature, Email Alerts, SNMP Traps
- Humidity Type:** Xytronix Model X-DTHS-P sensor
- Humidity Range:** 0-100% RH
- Accuracy:** $\pm 2\%$
- Max Cable Length:** 600 feet (180m) maximum combined cable length

Real-Time Clock

- Manual or NTP(Network Time Protocol) setup
- NTP Sync Period:** Once, Daily, Weekly, On Power-up
- Auto Daylight Savings Adjustment

Capacitor Power Backup

- Backup Functions:** Retain Real-Time Clock, External Variables, Relay State, and Counters
- Backup Duration:** 3 days minimum

Network

- Type:** 10/100 Base-T Ethernet Port
- Setup:** Static IP address assignment. TCP port selectable

Connectors

- Power/Input/Relays:** 14-Position, 3.81mm, Removable
- Network:** 8-pin RJ-45

LED Indicators

- Number of LEDs:** 5
 - Power on, I/O (1-2), Network linked, Network activity

Physical

- Operating Temperature:** -40°F to 150°F (-40°C to 65.5°C)
- Size:**
 - 1.41 in (35.7mm) wide x 3.88in (98.5mm) tall x 3.1in (78mm) deep (not including connector)
- Weight:** 5 oz (142 grams)
- Enclosure Material:** Lexan 940 Polycarbonate Plastic
- Enclosure Flame Rating:** UL94 V0

Protocols

- HTTP, HTTPS, SSL, XML, Modbus TCP/IP, SNMP, SMTP, Remote Services

Logging

- Log File Size:** 3072K (up to 50,688 log entries depending on configuration)
- Storage:** Nonvolatile Flash
- Buffer Architecture:** Circular Buffer
- Log data can be periodically read and stored on a computer

Advanced Features

- Task Builder, BASIC interpreter, Remote services

Password Settings

- Password protection on setup page:** Yes
- Password protection on control page:** Optional
- Password Encoding:** Base 64
- Max Password Length:** 18 Characters

Electromagnetic Compliance

- IEC CISPR 22, CISPR 24
- EU EN55024, EN55022
- X-418-I: FCC 47CFR15 (Class B)
- X-418-E: FCC 47CFR15 (Class A)



Product Safety Compliance

- IEC 61010-1

PRODUCT OVERVIEW

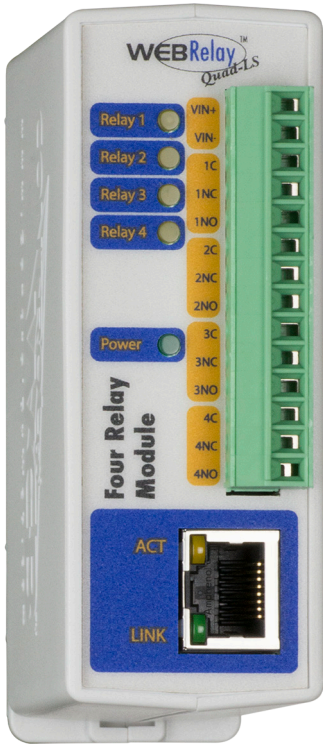

For many applications, WebRelay-Quad™ is the fastest, easiest, least expensive, and most reliable way to remotely control equipment over an IP network, including the Internet.

WebRelay-Quad™ is used by many different companies for hundreds of applications such as industrial control, security, remote control, remote reset, and much more.

It has four low-signal relays that can individually switch up to 3-Amp at 28V.

Each relay can be turned on, off, or pulsed using the built-in web pages or by running custom scripts from a computer or dedicated controller.

It is extremely versatile and can be made to fit almost any remote relay control need.

The WebRelay-Quad™ is fully configured in minutes using a web browser. No additional software is needed.

Features:

- Built-in web server for setup and remote relay control from a web-browser.
- No special software or device drivers required.
- XML status and control pages makes communications with custom software applications simple.
- Can operate as Modbus TCP/IP slave device.
- Four independent, 28VAC, 24VDC, 3-Amp Relays (SPDT).
- On/Off and Pulse modes.
- Rugged DIN-Rail/wall mountable enclosure.
- Includes a 14-pin industrial terminal connector.
- Power Supply Options:
 - 9-28 VDC
 - Power-Over-Ethernet (802.3af) or 5VDC

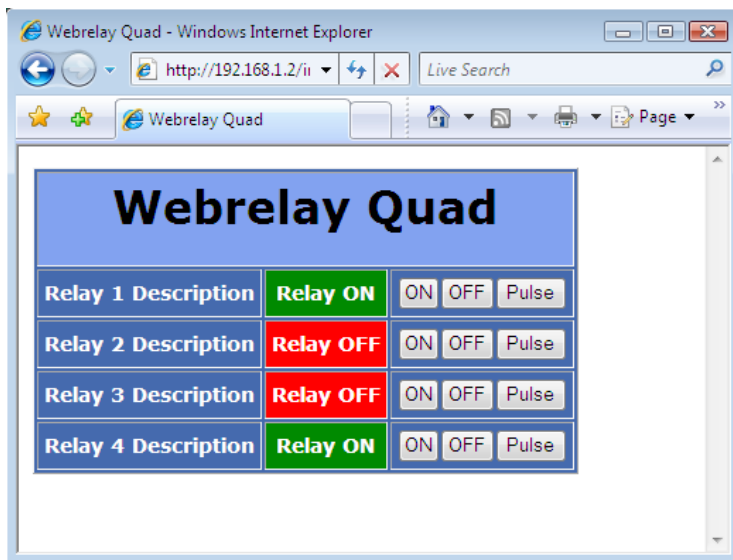

Relay Options

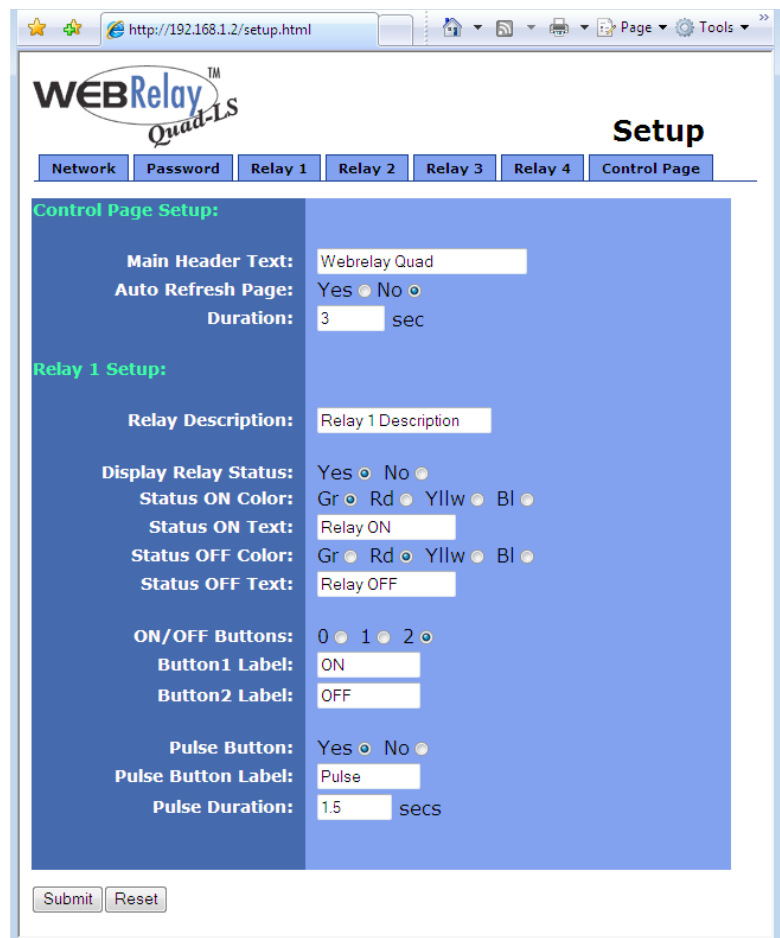

Individual Relay Options

APPLICATIONS & SPECS

Four-Color Light Tower Control

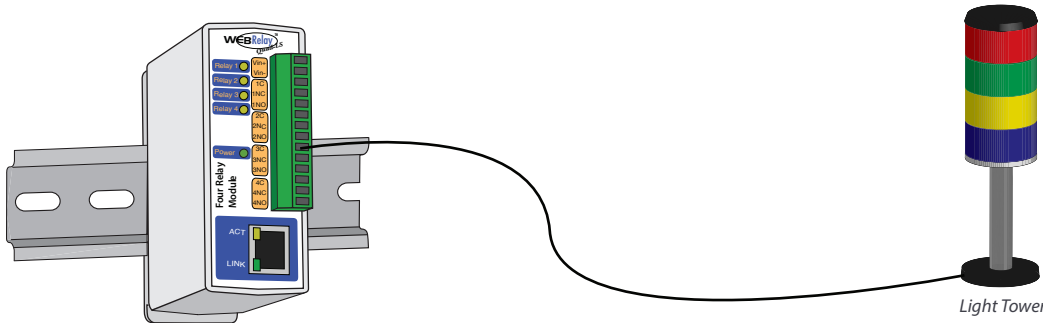

Additional Applications

- ✓ Industrial Control
- ✓ Remote Reset
- ✓ Security
- ✓ Remote Control
- ✓ More...

Use with Five-Input Module to Extend Dry Contacts to a Remote Location



Models:

- X-WR-4R3-I, X-WR-4R3-E

Power Requirements

- Voltage:
 - X-WR-4R3-I: 9-28VDC
 - X-WR-4R3-E: POE Class 1 (0.44 to 3.84 Watt) or 5V±5%
- Max Current:
 - X-WR-4R3-I: 320mA Max
 - X-WR-4R3-E: 477mA Max

Relay Contacts

- Number of Relays: 4
- Max Voltage: 28VAC, 24VDC
- Max Current: 3A
- Contact Type: SPDT (Form 1C)
- Load Type: General Purpose
- Contact Resistance: < 50 milliohms initial
- Contact Material: AgSnO2
- Electrical Life: 100K cycles (Typical)
- Mechanical Life: 10M cycles (Typical)
- Environmental Rating: Over voltage Category II, Pollution Degree 2
- Relay Modes: ON/OFF or Pulse
- Pulse Timer Duration: 0.1 to 86,400 Seconds (1-day)

Network

- Type: 10/100 Base-T Ethernet Port
- Setup: Static IP address assignment. TCP port selectable

Connectors

- Power & Relays 1-4: 14-Position, 3.81mm, Removable
- Network: 8-pin RJ-45

LED Indicators

- Number of LEDs: 7
 - Power on
 - Relay coil energized 1-4
 - Network linked
 - Network activity

Physical

- Operating Temperature: -40°F to 150°F (-40°C to 65.5°C)
- Size:
 - 1.41in (35.7mm) wide
 - 3.88in (98.5mm) tall
 - 3.1in (78mm) deep (not including connector)
- Weight: 5 oz (142 grams)
- Enclosure Material: Lexan 940 Polycarbonate Plastic

- Enclosure Flame Rating: UL94 V0

Protocols

- HTTP, XML, Modbus

Password Settings

- Password protection on setup page: Yes
- Password protection on control page: Optional
- Password Encoding: Base 64
- Max Password Length: 10 Characters

Electromagnetic Compliance

- IEC CISPR 22, CISPR 24
- EU EN55024, EN55022
- X-WR-4R3-I: FCC 47CFR15 (Class B)
- X-WR-4R3-E: FCC 47CFR15 (Class A)

Product Safety Compliance

- IEC 61010-1



PRODUCT OVERVIEW

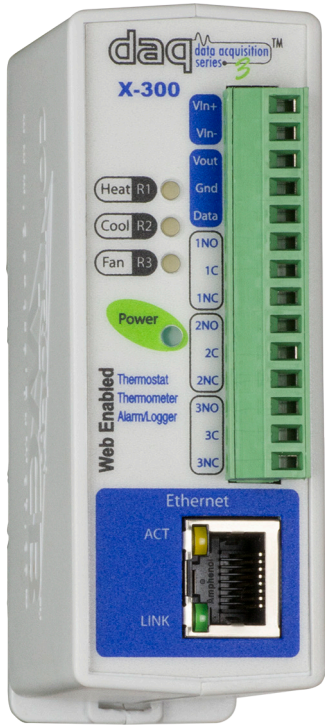

The X-300™ is two products in one package!

First, the X-300™ is a powerful web-based temperature logging instrument that allows you to monitor temperatures via an IP network.

Up to eight temperature/humidity sensors can be connected at a time, and temperature/humidity can be viewed in real-time using a web browser.

It has three relays that can be used for control of fans, heaters, coolers, or just about anything. Relay control can be based upon temperature or can be independent.

In addition, the X-300™ has many advanced features including email alerts, relay control, a BASIC interpreter, and much more.

Second, the X-300™ is a 7-day programmable web-enabled thermostat. Users can adjust and set temperatures for heating and cooling systems and view current indoor and outdoor temperatures from any web browser.

As a web-enabled thermostat, it provides an attractive control web page that works great on desktop computers as well as most web-enabled smartphones.

Features:

- Web-browser based - no software required.
- Self contained - no external server or services required.
- Email alerts.
- Three, 3-Amp relays.
- Built-In real-time clock w/ capacitor backup.
- Temperature Logger.
- Supports HTTP, TCP, SNMP, Modbus TCP/IP.
- Supports additional data logging and management from web services.
- Internal temperature and voltage monitoring for diagnostics.
- Wide operating temperature range.
- Removable terminal connector for convenient wiring.
- Field updatable.
- Rugged DIN-Rail/wall mountable enclosure.

Temp/Humidity Logger:

- The temperature logger can receive data from up to eight sensors (one temperature sensor included).
- Both temperature and humidity sensors are supported.
- Supports BASIC scripts for advanced configuration.

Thermostat:

- Attractive thermostat user interface.
- Connect up to two temperature sensors (indoor and outdoor).
- 7-day programming schedule.
- Connect to single stage heating/cooling system.

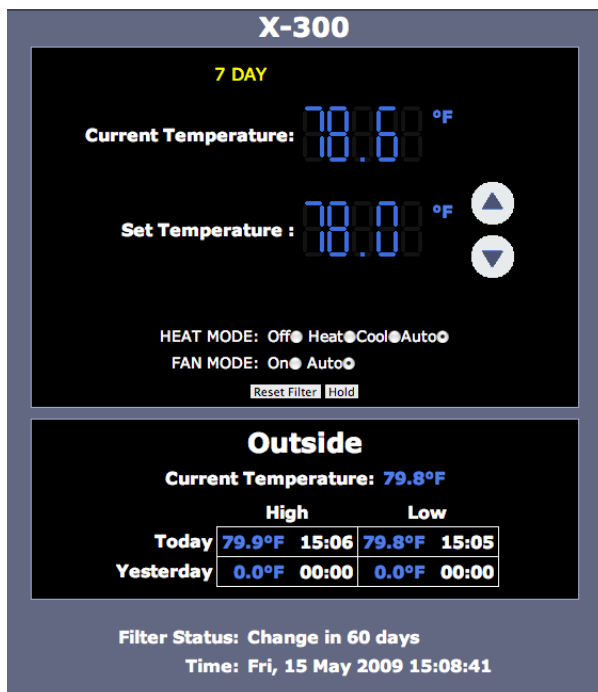

Control Page User Interface

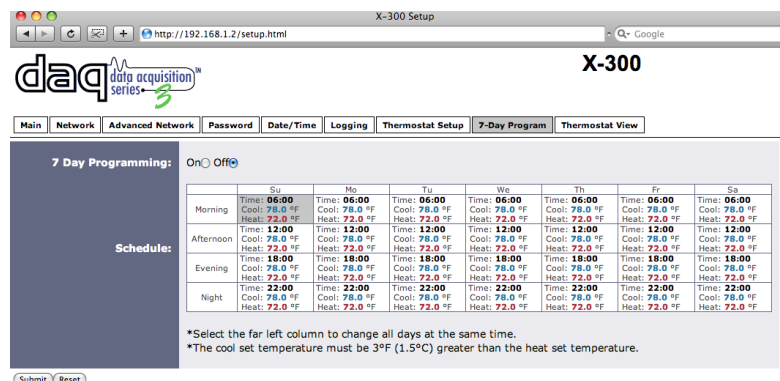

7-Day Programmable Schedule

APPLICATIONS & SPECS

Remote Temperature Monitoring/Logging

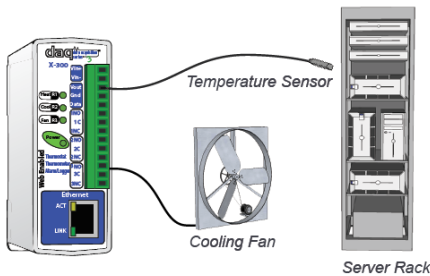

Models:

- X-300-I+PS12-A, X-300-I, X-300-E

Power Requirements:

- **Voltage:**
 - X-300-I: 9-28 VDC
 - X-300-E: POE Class 1 (0.44 to 3.84 Watts)
- **Current:** 44mA - 374mA*

*Current based upon voltage applied and device settings. See users manual for complete breakdown.

Relays

- **Number of Relays:** 3
- **Max Voltage:** 28VAC, 24VDC
- **Max Current:** 3A
- **Contact Type:** SPDT (Form 1C)
- **Load Type:** General Purpose
- **Contact Resistance:** < 50 milliohms initial
- **Contact Material:** AgSnO2
- **Electrical Life:** 100K cycles (Typical)
- **Mechanical Life:** 10M cycles (Typical)
- **Environmental Rating:** Over voltage Category II, Pollution Degree 2
- **Relay Modes:** ON/OFF or Pulsed
- **Pulse Timer Duration:** 0.1 to 86,400 Seconds (1-day)

Temperature Sensors

- **Maximum Number of Sensors:** 8
- **Type:** Dallas Semiconductor DS18B20
- **Temperature Range:** -67°F to 257°F (-55°C to +125°C)
- **Accuracy:** ±0.5°C (from -10°C to +85°C)
- **Sensor Functions:** Thermometer, Thermostat, Relay Control, Remote Relay Control, Email Alarms, SNMP Traps, Temperature Logging
- **Humidity Type:** Xytronix Model X-DTHS-WM wall mount sensor
- **Humidity Range:** 0-100% RH
- **Accuracy:** ±1.8%

Real-Time Clock

- Manual or NTP(Network Time Protocol) setup
- **NTP Sync Period:** Once, Daily, Weekly, On Power-up

Web-Enabled Thermostat

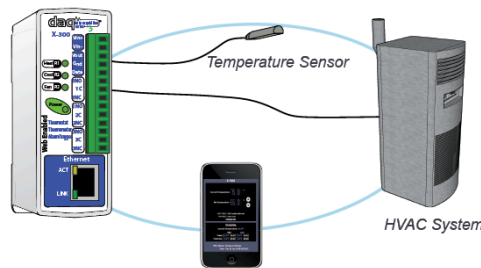

- Auto Daylight Savings Adjustment
- Battery (capacitor) Power Backup

Capacitor Power Backup

- **Backup Functions:** Retain Real-Time Clock, External Variables, Relay State, and Counters
- **Backup Duration:** 3 days minimum

Network

- **Type:** 10/100 Base-T Ethernet Port
- **Setup:** Static IP address assignment. TCP port selectable

Connectors

- **Power, Outputs, and Inputs:** 14-Position, 3.81mm, Removable
- **Network:** 8-pin RJ-45

LED Indicators

- **Number of LEDs:** 6
 - Power on
 - Relay coil energized 1-3
 - Network linked
 - Network activity

Physical

- **Operating Temperature:** -40°F to 150°F (-40°C to 65.5°C)
- **Size:**
 - 1.41in (35.7mm) wide
 - 3.88in (98.5mm) tall
 - 3.1in (78mm) deep (not including connector)
- **Weight:** 5 oz (142 grams)
- **Enclosure Material:** Lexan 940 Polycarbonate Plastic
- **Enclosure Flame Rating:** UL94 V0

Additional Applications

- ✓ **Server Rooms**
- ✓ **Freezers**
- ✓ **Green Houses**
- ✓ **Vacation Homes**
- ✓ **Refrigeration Systems**
- ✓ **Apartment Complexes**
- ✓ **Car Washes**
- ✓ **More...**

Protocols

- HTTP, XML, Modbus, SNMP, SMTP, Remote Services

Logging

- **Log File Size:** 512K min 11,049 logs
- **Storage:** Nonvolatile Flash
- **Buffer Architecture:** Circular Buffer
- Log data can be periodically read and stored on a computer

Advanced Features

- BASIC interpreter
- Remote services - Avoid most firewall issues with outbound connection to Web Services

Password Settings

- **Password protection on setup page:** Yes
- **Password protection on control page:** Optional
- **Password Encoding:** Base 64
- **Max Password Length:** 13 Characters

Electromagnetic Compliance

- IEC CISPR 22, CISPR 24
- EU EN55024, EN55022
- X-300-I: FCC 47CFR15 (Class B)
- X-300-E: FCC 47CFR15 (Class A)

Product Safety Compliance

- IEC 61010-1



PRODUCT OVERVIEW

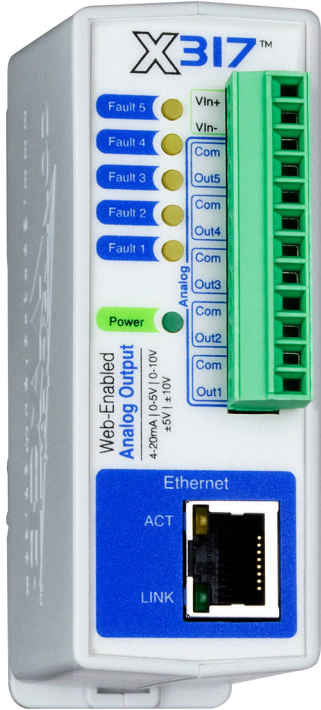

The X-317™ is a web-enabled analog output module with five output channels. The analog outputs are similar to that of a Programmable Logic Controller (PLC). However, unlike a PLC, the X-317 is designed for web-based applications from the ground up. No add-on software or hardware is required.

The X-317 can be fully configured, programmed, and tested using its built-in web server. The web setup pages are intuitive and easy-to-use and do not require special programming skills.

The X-317 can be used as a stand-alone device or can operate as a peripheral for other devices such as a programmable logic controller (PLC) or the X-600M™.

The X-317 has five precision 16-bit digital to analog converters (DACs). Each channel can be programmed for 0-5V, 0-10V, ±5V,

±10V, 4-20mA ranges. The voltage and current outputs for each channel are on a single connector terminal,.

Most industrial analog applications require isolation between the power supply and analog outputs. The X-317 has a built-in DC-DC converter for providing isolated power to the outputs. No external isolated back plane power is needed.

The built-in web setup pages allow the name and settings for each channel to be configured. You can configure the range of a setting to be in engineering units. For example, an input value of 0 to 100% can be scaled and processed for an output range of 4 to 20mA to control a damper motor.

Features:

- Built with:
 - Industrial grade components
 - High-reliability SLC flash
 - Transient protection
 - Watchdog timers
 - Voltage supervisor circuitry, etc.
- Five separate analog output channels
- 0-5V, 0-10V, ±5V, ±10V, 4-20mA output ranges
- Outputs are software configured, independently programmable, and scalable
- Built-in isolated DC-DC converter
- Wide power supply range (9-28VDC)
- No special software or device drivers required
- Built-in password protected web setup and control pages
- Static or DHCP IP address configuration
- XML, Modbus TCP/IP, & SNMP interface options
- Field updatable
- Removable terminal connector
- Rugged DIN-Rail/wall-mountable enclosure

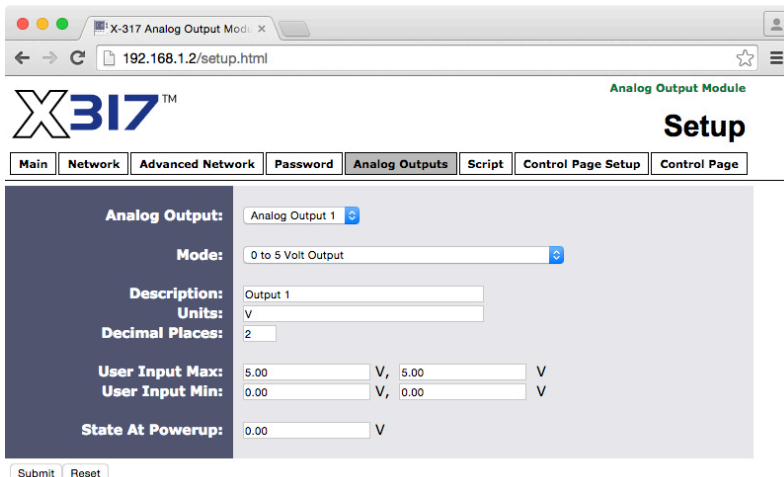

Analog Output Configuration Tab

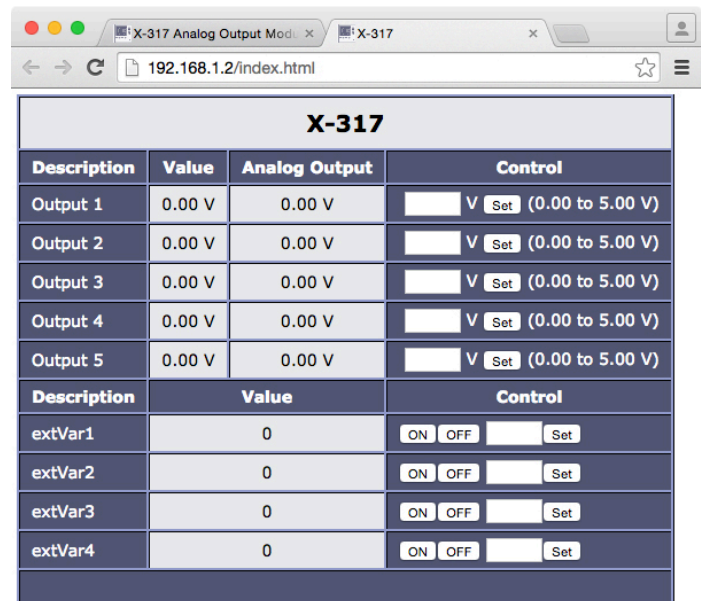

X-317 Control Page

APPLICATIONS & SPECS

X-317 Controlling Conveyor Belt Through X-600M/Computer

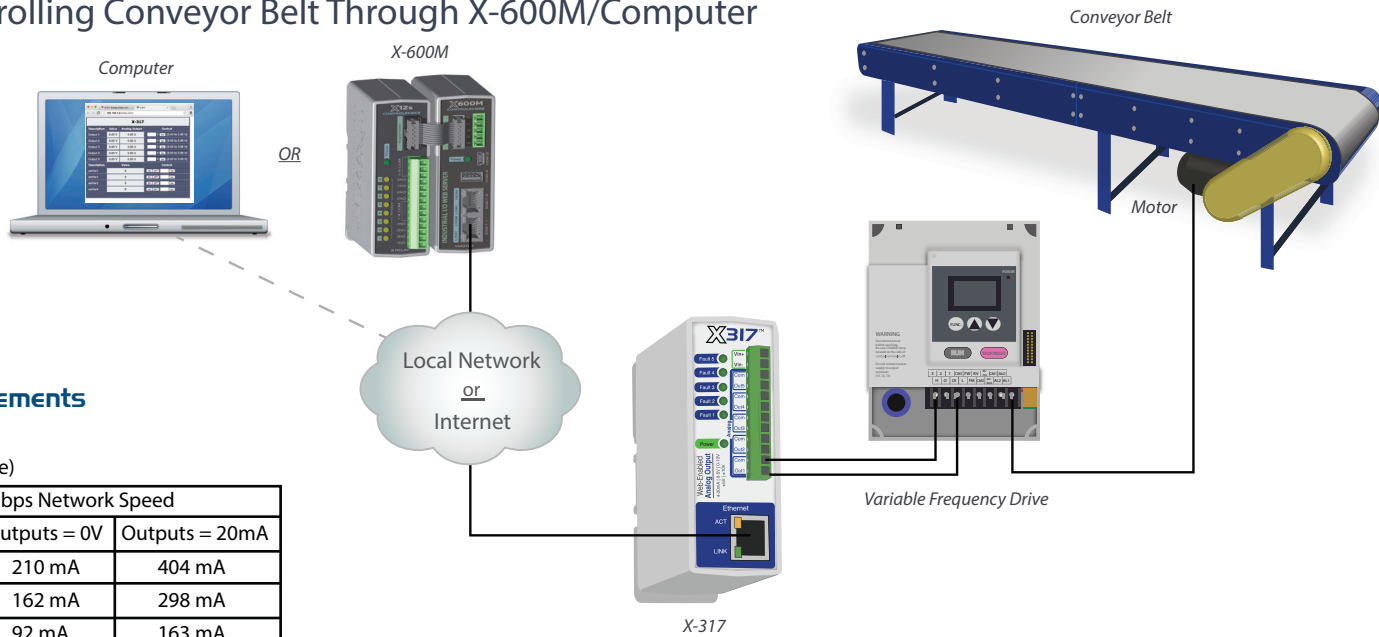

Models:

- X-317-I

Power Requirements

- Voltage: 9-28VDC
- Max Current: (table)

10 Mbps Network Speed		
Power Supply	Outputs = 0V	Outputs = 20mA
9 VDC	210 mA	404 mA
12 VDC	162 mA	298 mA
24 VDC	92 mA	163 mA

100 Mbps Network Speed		
Power Supply	Outputs = 0V	Outputs = 20mA
9 VDC	302 mA	498 mA
12 VDC	229 mA	368 mA
24 VDC	126 mA	198 mA

Analog Inputs

- Number of channels: 5 (Individually configurable)
- Output Ranges: 0-5V, 0-10V, $\pm 5V$, $\pm 10V$, 4-20mA (software selectable)
- Resolution: 16-bit DAC (0-65535)
- Linearity Error: ± 1 -count, monotonic DAC
- Current Output (Voltage Mode): 10mA max (min load = 1K), 30mA max short circuit
- Voltage Output Inaccuracy: $\pm 0.2\%$ FSR includes offset error, gain error and non-linearity error, -40 to 65°C
- Max Load Capacitance: 20nF (no load), 5nF (1K load)
- Current Output Range: 4-20mA
- Current Output Inaccuracy: $\pm 0.2\%$ FSR includes offset error, gain error and non-linearity error, -40 to 65°C
- Output Compliance Voltage: 11.50V min (max loop voltage)
- Isolated Power Supply: Internal DC-DC converter
- Isolation: Galvanic, 1500 VAC
- ESD Protection: Integrated 15kV protection (IEC61000-4-2)
- Output Protection: Integrated over-temperature, open-line and short circuit protection
- Output Alarms: Open current loop, high internal temperature
- Load Type: Grounded, COM of all 5-channels are connected together
- Output at power up: Programmable

Network

- Type: 10/100 Base-T Ethernet Port
- Setup: Static IP address assignment or DHCP, HTTP port selectable

NONVOLATILE MEMORY

- All user settings are stored in nonvolatile memory. Settings will not be lost when power is disconnected.

Connectors

- Power, & Outputs: 12-Position, 3.81 mm, Removable
- Network: 8-pin RJ-45

LED Indicators

- Number of LEDs: 8
 - Power on
 - Fault condition (channels 1-5)
 - Network linked
 - Network activity

Physical

- Operating Temperature: -40°F to 150°F (-40°C to 65.5°C)
- Storage Temperature: -40°F to 185°F (-40°C to 85°C)
- Size:
 - 1.41in (35.7mm) wide
 - 3.88in (98.5mm) tall
 - 3.1in (78mm) deep (not including connector)
- Weight: 4.8 oz (136 g)
- Enclosure Material: Lexan 940 Polycarbonate Plastic
- Enclosure Flame Rating: UL94 V0

Protocols

- HTTP, XML, Modbus TCP/IP

Password Settings

- Password protection on setup page: Yes
- Password protection on control page: Optional
- Password Encoding: Base 64
- Max Password Length: 13 Characters

Electromagnetic Compliance

- IEC CISPR 22, CISPR 24
- FCC 47CFR15 (Class B)
- EN55024 ITE Immunity (2010)
- EN55022 Emissions (2010)

Product Safety Compliance

- IEC 61010-1





The X-332™ is a robust, full-featured, web-enabled Ethernet I/O module. It has 16 relays, 16 optically-isolated digital inputs, 2 counter inputs, 4 analog inputs, support for up to four temperature and/or humidity sensors, and the ability to control relays remotely on other ControlByWeb devices. It also has many additional features such as a full calendar scheduler, a BASIC script interpreter, logging, and a real-time clock with NTP synchronization.

The X-332™ has a built-in web server so its relays and inputs can be controlled and monitored using a standard web browser (or by using our CBW Mobile smartphone app). Additionally, temperature and humidity data can be graphed directly from any HTML5 compatible web browser. Email alerts can be configured based on relay and/or input states, and temperature/humidity thresholds.

Some of its many advanced features include the ability to initiate a connection to remote servers, BASIC programming, SNMP, peer-to-peer communications, internal monitoring, etc.

This module is ideal for many applications including security, lighting control, remote control, shift bell controllers, and much more.

Simply access and configure the X-332™ by using its web-based user interface. There is no software required, no subscription to buy, and no programming necessary for setup or use.

Features:

- 16 electro-mechanical relays (2 Amp contacts)
- 16 optically-isolated digital inputs
- 2 counter inputs
- 4 analog inputs
- One-wire bus for up to 4 temperature and/or humidity sensors
- Control up to 16 relays on other ControlByWeb devices
- Monitor and log power supply (voltage)
- Highly configurable - almost any combination of input/relay control possible
- Real-Time Clock with NTP server synchronization
- Automatic daylight savings and leap year adjustment
- Full calendar scheduling with 100 programmable events
- Email alerts based on user-defined conditions
- Built-in web server - No software required
- Customizable web-based control page
- BASIC script support for advanced flexibility
- Configurable logging
- Graphing (logged data)
- Static or DHCP IP address configuration
- XML, Modbus TCP/IP, and SNMP interface options
- Field updatable
- Removable terminal connector for easy installation
- Rugged DIN-Rail/wall-mountable enclosure



Control Page

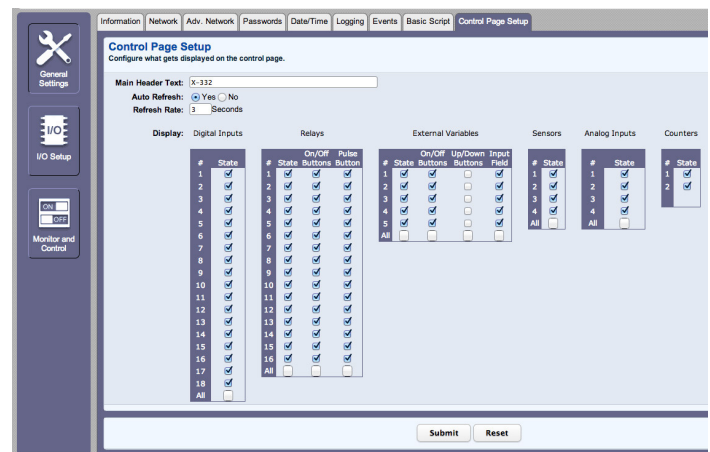

Control Page Setup

APPLICATIONS & SPECS

Models:

- X-332-241

Power Requirements

- Voltage: 9-28VDC
- Max Current: 1.16A Max

Relay Contacts

- Number of Relays: 16
- Max Voltage: 30VDC, 30VAC
- Max Current: 2A
- Contact Type: SPST (Form 1A)
- All Relays have a shared common
- Load Type: General Purpose
- Contact Resistance: < 100 milliohms initial
- Contact Material: AgSnO₂
- Electrical Life: 100K operations (Min)
- Mechanical Life: 5M cycles (Min)
- Environmental Rating: Over voltage Category II, Pollution Degree 2
- Relay Modes: ON/OFF or Pulsed
- Pulse Timer Duration: 0.1 to 86,400 Seconds (1-day)

Digital Inputs

- Number of Inputs: 16
- Type: Optically-Isolated
- Voltage Range: 3-26VDC
- Current: 0.6mA @ 3V, 8.2mA @ 26V
- Minimum Hold Time: 20ms
- Input Isolation: 1500V
- Input Functions: Monitor State, Control Relays, Control Remote Relays, High Timer

Counter Inputs

- Number of Inputs: 2
- Type: Non-Isolated
- Voltage Range: 0-5VDC
- Current: 47K Pullup
- Minimum Hold Time: 20ms
- Input Isolation: Non-Isolated
- Input Functions: Monitor State, Control Relays, Control Remote Relays, Count, High Timer
- Maximum Count: 32-bit
- Max Count Rate: 25Hz Max
- Edge Trigger: Rising, Falling or Both

Analog Inputs

- Number of Inputs: 4
- Type: Single-ended Channels
- Input Range: 0-5VDC
- Resolution: 12-bit
- Reference: 5.00V, 0.04%, 3ppm/C, 50mA Max

Additional Applications

- ✓ Real-Time Clock
- ✓ Scheduling
- ✓ Logging
- ✓ Email Notifications

TEMPERATURE/HUMIDITY SENSORS

RELAYS

- Motors
- Alarms
- Lights
- Valves
- Pumps
- Locks
- Equipment

ANALOG INPUTS

- Pressure Sensor
- Frequency Sensor
- Wind Speed Sensor
- Flow Sensor

DIGITAL INPUTS

- Switches
- Moisture Sensors
- Door Sensors
- Motion Detectors
- Window Sensors

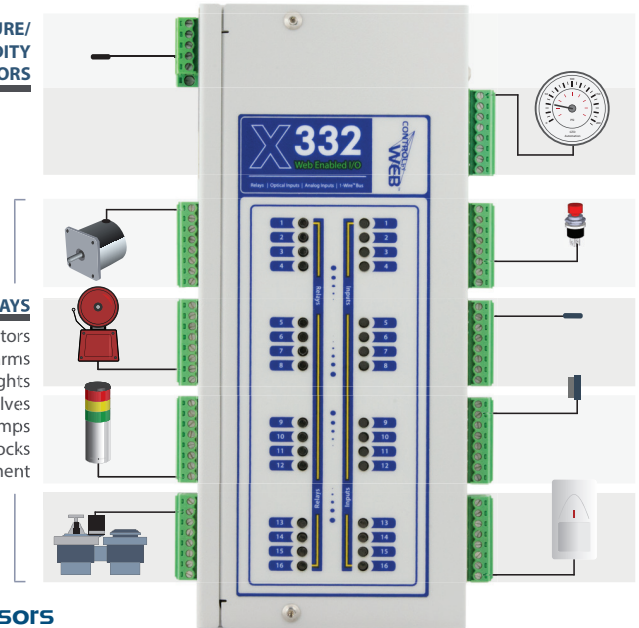

Temperature Sensors

- Maximum Number of Sensors: 4
- Type: Dallas Semiconductor DS18B20
- Temperature Range: -67°F to 257°F (-55°C to +125°C)
- Accuracy: ±0.5°C (from -10°C to +85°C)
- Sensor Functions: Thermometer, Thermostat, Relay Control, Remote Relay Control, Email Alerts, SNMP Traps, Temperature Logging
- Humidity Type: Xytronix Model X-DTHS-WM wall mount sensor
- Humidity Range: 0-100% RH
- Accuracy: ±1.8%

Real-Time Clock

- Manual or NTP(Network Time Protocol) setup
- NTP Sync Period: Once, Daily, Weekly, On Power-up
- Auto Daylight Savings Adjustment
- Battery (capacitor) Power Backup

Capacitor Power Backup

- Backup Functions: Retain Real-Time Clock, External Variables, Relay State, and Counters
- Backup Duration: 3 days minimum

Network

- Type: 10/100 Base-T Ethernet Port
- Setup: Static or DHCP IP address configuration

Connectors

- Power: 3-Position, 3.81mm, Removable
- Relays & Inputs: 8-Position, 3.81mm, Removable
- Network: 8-pin RJ-45

LED Indicators

- Number of LEDs: 35
 - Power on
 - Relay coil energized 1-16
 - Digital inputs (1-16)
 - Network linked
 - Network activity

Physical

- Operating Temperature: -40°F to 150°F (-40°C to 65.5°C)
- Size:
 - 8.725in (221.6mm) wide
 - 1.815in (46.1mm) tall
 - 3.735in (94.9mm) deep (not including connector)
- Weight: 31.3 oz (887.3 grams) with connectors
- Material: Powder-Painted Steel

Protocols

- HTTP, XML, Modbus TCP/IP, SNMP, SMTP, Remote Services

Logging

- Log File Size: 512K (max 28,829 logs)
- Storage: Nonvolatile Flash
- Buffer Architecture: Circular Buffer
- Log data can be periodically read and stored on a computer

Advanced Features

- Data Graphing
- BASIC interpreter
- Remote services

Password Settings

- Password protection on setup page: Yes
- Password protection on control page: Optional
- Password Encoding: Base 64
- Max Password Length: 13 Characters

Electromagnetic Compliance

- IEC CISPR 22, CISPR 24
- EU EN55024, EN55022
- FCC 47CFR15 (Class B)

Product Safety Compliance

- IEC 61010-1



PRODUCT OVERVIEW



The X-400™ is a powerful web-enabled industrial I/O controller with advanced logic and modular expansion capabilities.

The X-400 can be programmed either by using its web-page-based “Task Builder” or by writing a BASIC script. The X-400 can be expanded by simply attaching I/O expansion modules to its expansion bus, or it can seamlessly share I/O on other ControlByWeb devices over the Ethernet network.

Monitor Temperature & Humidity

Connector terminals provide communication with 1-Wire sensors to monitor temperature and humidity.

Directly Connected I/O

A ribbon cable expansion bus connector allows up to 32 expansion modules (X-11s, X-12s, X-13s, etc.) to be connected directly

to the X-400 without the need for an Ethernet switch. Various expansion modules are available with relays, digital inputs, thermocouples, analog inputs, etc. All expansion modules available for the X-600M can also be used with the X-400 controller.

Remote I/O

The X-400 can also seamlessly communicate and share I/O with any other X-400 series modules (X-410, X-418, etc.) through the TCP/IP network. This remote I/O can be used by the X-400 for any function and works the same as if the I/O was directly connected to the X-400 controller.

Built-in Web Server

Users can operate the X-400 using a web browser, the CBW Mobile app, or custom applications written for a computer, PLC, or other automation controller. No gateways, cloud servers, or external services are required.

Cloud Server (Optional)

The X-400 can, however, be used with our ControlByWeb.cloud cloud service if desired which simplifies network setup. The X-400 supports standard HTTP requests or encrypted HTTPS requests.

Control/Logic Task Builder

Easily program up to 50 Scheduled task, 50 Conditional tasks, 20 Automatic Reboot tasks, and 20 Override Schedules.

User Permissions

The X-400 supports three types of users that provide different levels of access to the device’s settings and Control Pages.

Visit our website to learn more about the X-400’s many exciting features:

<https://www.controlbyweb.com/x400/>

Features:

- Expansion Bus - Control, monitor, and log 32 expansion and/or remote modules, or up to 100 I/O
- Secure Peer-to-Peer (P2P) Communication
- 1-Wire Bus: Monitor up to 16 temp/humidity sensors: -67°F to 257°F (-55°C to +125°C)
- Secure, built-in web server for configuration and remote monitoring
- User Permissions: Admin, Manager, User
- Task Builder (50 Scheduled Tasks, 50 Conditional Tasks, 20 Reboot Tasks, 20 Override Schedules)
- Send email alerts based on user-defined conditions (supports encrypted email servers, such as Gmail)
- Real-Time Clock with NTP server synchronization
- Automatic daylight savings and leap year adjustment
- Highly configurable - Almost any combination of input/relay control possible
- No software required
- Customizable, web-based Control Page
- BASIC script support for advanced flexibility
- Data Logging & Graphing (logged data)
- HTTPS/TLS encrypted
- Static or DHCP IP address configuration
- Modbus, SNMP, Remote Service, IP Filtering
- Field updatable
- Removable 14-Terminal connector for easy installation
- Rugged DIN-Rail/wall-mountable enclosure

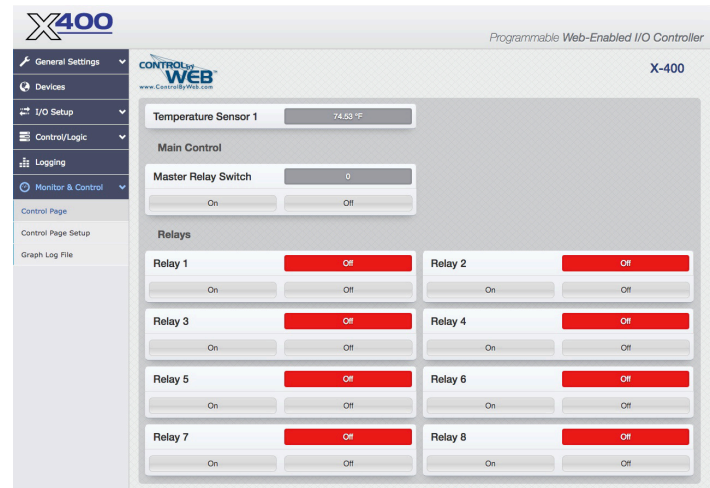

Web-Based Control Page Example

APPLICATIONS & SPECS

Sports Web-Based Lighting Controller with Scheduling

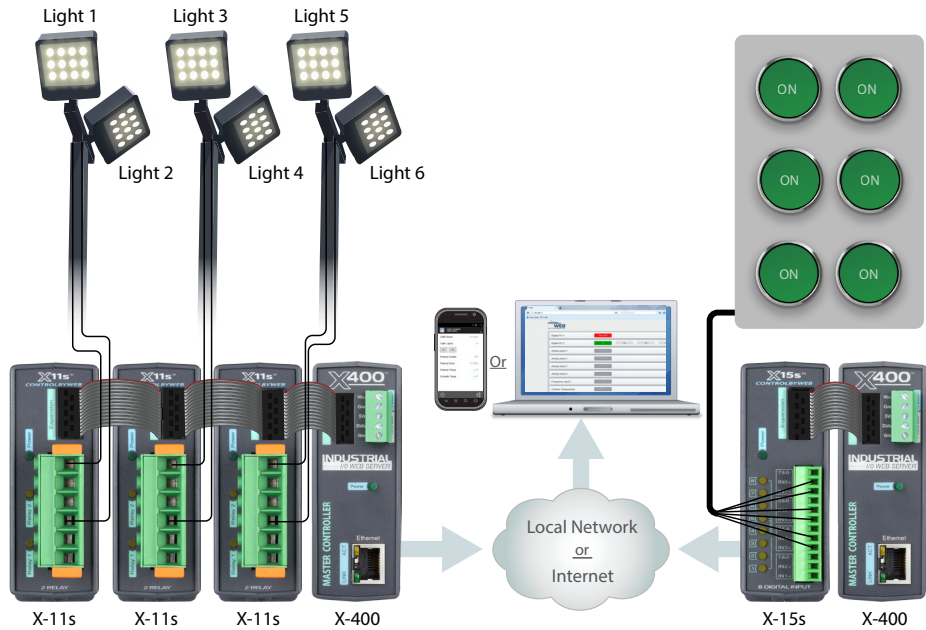

Additional Features

- ✓ Expandable, up to 100 I/O points
- ✓ Task Builder for light scheduling
- ✓ Easy, configurable web pages
- ✓ Custom email/text notifications
- ✓ More...

Models:

- X-400-I

Power Requirements

- Voltage: 9-28VDC
- Max Current: See table below for typical values at 25°C, 10/100Mbps.

Power Supply	Input Current (no expansion modules)	Input Current (X-400 + 1.7A for expansion modules)
9 VDC	134 mA	1.834 A
12 VDC	101 mA	1.801 A
24 VDC	55 mA	1.755 A

Voltage Outputs

- Expansion Bus (X-400-I): 1.7A max

Temperature Sensors

- Maximum Number of Sensors: 16
- Type: Dallas Semiconductor DS18B20 digital 1-Wire thermometer
- Temperature Range: -67°F to 257°F (-55°C to +125°C)
- Accuracy: ±0.5°C (from -10°C to +85°C)
- Sensor Functions: Monitor Temperature, Log Temperature, Email Alerts, SNMP Traps
- Humidity Type: Xytronix Model X-DTHS-P sensor
- Humidity Range: 0-100% RH
- Accuracy: ±2%
- Max Cable Length: 600 feet (180m) maximum combined cable length

Real-Time Clock

- Manual or NTP(Network Time Protocol) setup
- NTP Sync Period: Once, Daily, Weekly, On Power-up
- Auto Daylight Savings Adjustment
- Battery (capacitor) Power Backup

Capacitor Power Backup

- Backup Functions: Retain Real-Time Clock, 1 Register, 2 Counters, 64 Relay States (local and expansion relays only)
- Backup Duration: 2 week minimum

Nonvolatile Memory

- Industrial grade eMMC NANDrive, single level cell (SLC)
- All user settings are stored in nonvolatile memory. Settings will not be lost when power is disconnected.

Network

- Type: 10/100 Base-T Ethernet Port
- Setup: Static or DHCP IP address configuration

Connectors

- Power and 1-Wire Bus: 5-Position, 3.81mm, Removable
- Expansion Bus: Ribbon cable, 10-conductor, polarized, 2x5-position, 0.100" pitch Provides power and communications for expansion modules (Communications: RS-485)
- Network: 8-pin RJ-45

LED Indicators

- Number of LEDs: 5
 - Power on
 - Network linked
 - Network activity

Physical

- Operating Temperature: -40°F to 150°F (-40°C to 65.5°C)
- Size:
 - 1.41in (35.7mm) wide
 - 3.88in (98.5mm) tall
 - 3.1in (78mm) deep (not including connector)
- Weight: 4.8 oz (136 g)
- Enclosure Material: Lexan 940 Polycarbonate Plastic
- Enclosure Flame Rating: UL94 V0

Protocols

- HTTP, HTTPS, SSL, XML, Modbus TCP/IP, SNMP V1,2C,V3, SMTP

Logging

- Log File Size: 3,072-Kbyte (up to 50,688 logs)
- Storage: Nonvolatile Flash
- Buffer Architecture: Circular Buffer (Log data can be periodically read and stored on a computer)

Advanced Features

- Task Builder
- BASIC interpreter (up to 4-Kbytes script file size)
- Remote services

Password Settings

- Password protection on setup page: Yes
- Password protection on control page: Optional
- Password Encoding: Base 64
- Max Password Length: 20 Characters

Electromagnetic Compliance

- IEC CISPR 22, CISPR 24
- FCC 47CFR15 (Class B)
- EN55024 ITE Immunity (2010)
- EN55022 Emissions (2010)

Product Safety Compliance

- IEC 61010-1



PRODUCT OVERVIEW



The X-600 series modular I/O controller is the ultimate drop-in solution for monitoring and control. Start with the X-600M controller and add I/O modules for a solution tailored to your specific application. This series has so many new features it is OUR BEST YET!

The X-600M™ is a multi-function web-enabled module for control and monitoring over the Internet. The X-600M performs control, logic, and monitoring functions similar to that of a Programmable Logic Controller (PLC). However, unlike a PLC, the X-600M is designed for web-based applications from the ground up.

The X-600M can be setup, controlled, and monitored using its built-in web server and a standard web browser. The web page setups are intuitive and easy to use

and do not require special programming skills. No add-on software or hardware is required.

The X-600M functions as a powerful master controller for other ControlByWeb™ modules. Its ribbon-cable expansion bus connector allows for up to 64 expansion modules to be connected directly to the X-600M. It can also control up to 128 other stand-alone ControlByWeb products.

Expansion I/O modules for the X-600M are available with relays, digital inputs, thermocouples, and more.

The features of other ControlByWeb products are also included, such as Email notification, scheduling, logging and graphing of logged data, custom Lua scripts, and much more.

Features:

- Powerful built-in web server
- Easily configurable web pages
- Logging & automatic graphing of log files
- Built-In Ethernet switch with two Ethernet Connections
- Expansion bus - Direct connection up to 64 modules (128 modules total)
- Communicates with all ControlByWeb modules
- Up to 1,024 I/O points
- Supports USB Wi-Fi adapters & USB flash drives
- Built-in 1-wire bus for temp/humidity sensors
- Send custom email alerts using encrypted email servers (Gmail, Yahoo, etc.)
- Create logic scripts or full programs using Lua
- Advanced, full-calender scheduling
- Protocols supported: HTTP, HTTPS, XML, SSL, SMTP, Modbus TCP/IP, Remote Services™ server and client, & more.
- Rugged DIN-rail mount enclosure
- Email alerts based on user-defined conditions
- Static or DHCP IP address configuration
- Field updatable
- Removable 14-Terminal connector
- Rugged DIN-Rail/wall-mountable enclosure

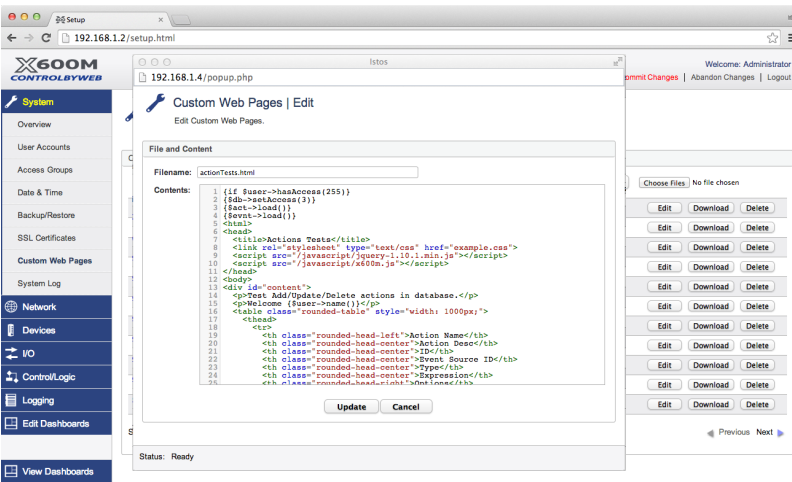

Edit Custom Web Pages

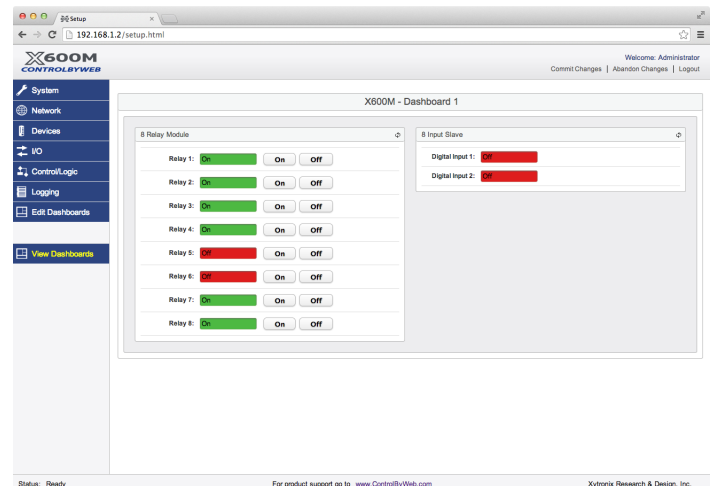

View Dashboards

APPLICATIONS & SPECS

Additional Features

- ✓ Expandable, up to 1,024 I/O points
- ✓ Expansion Bus
- ✓ Easy, configurable web pages
- ✓ Custom Email Notifications
- ✓ More...

Models:

- X-600M-I

Power Requirements

- Voltage: 9-28VDC
- Max Current: See table below for typical values at 25°C, 10/100Mbps.

Power Supply	Input Current (no expansion modules)
9 VDC	173 mA
12 VDC	132 mA
24 VDC	71 mA

Voltage Outputs

- Expansion Bus (X-600M-I): 1.7A max

USB

- Host: USB 2.0 Type A
- Device: USB 2.0 Mini-B

Temperature Sensors

- Maximum Number of Sensors: 32
- Type: Dallas Semiconductor DS18B20 digital 1-Wire thermometer
- Temperature Range: -67°F to 257°F (-55°C to +125°C)
- Accuracy: ±0.5°C (from -10°C to +85°C)
- Sensor Functions: Monitor Temperature, Control Expansion Module's Relays, Control Remote Relays, Log Temperature, Email Alerts
- Humidity Type: Xytronix Model X-DTHS-WM wall mount sensor
- Humidity Range: 0-100% RH
- Accuracy: ±1.8%

Real-Time Clock

- Manual or NTP(Network Time Protocol) setup
- NTP Sync Period: Once, Daily, Weekly, On Power-up
- Auto Daylight Savings Adjustment
- Battery backup (super capacitor), 30 days min
- Accuracy ±10 seconds/month

Shift Bell Controller

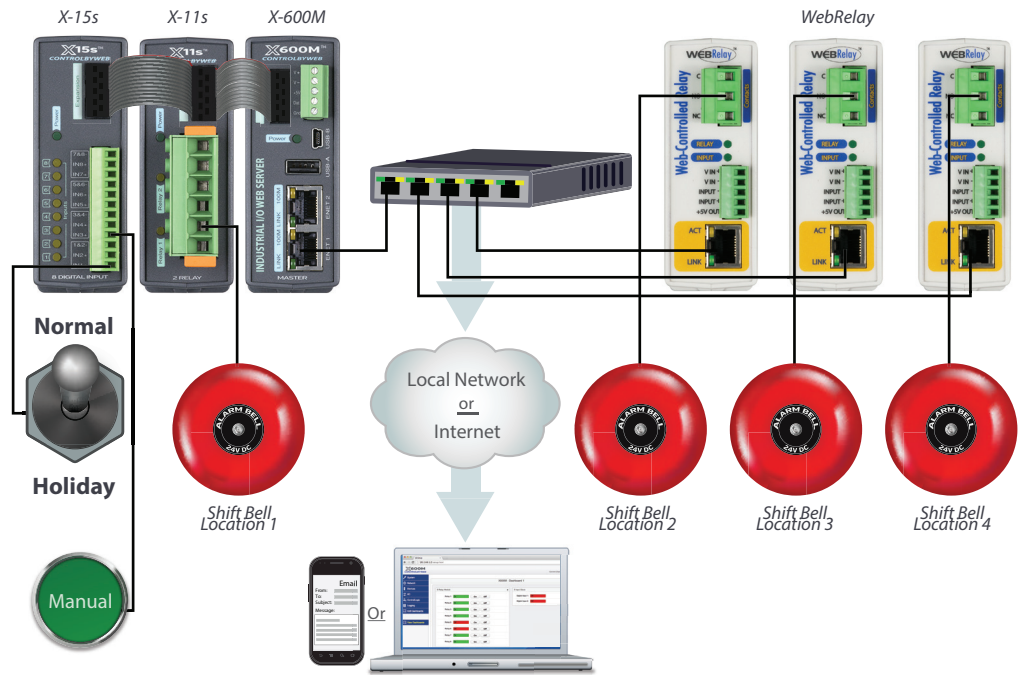

Nonvolatile Memory

- Industrial grade eMMC NANDrive, single level cell (SLC)
- All user settings are stored in nonvolatile memory. Settings will not be lost when power is disconnected.

Network

- 2ea 10 Base-T or 100 Base-T, 8-pin RJ-45 Ethernet connectors. Built-in 3-port L2 switch
- Setup: Static or DHCP IP address configuration

Connectors

- Power & Inputs: 5-Position, 3.81mm, Removable
- Expansion Connector: Ribbon cable, 10-conductor, polarized, 2x5-position, 0.100" pitch Provides power and communications for expansion modules (Communications: RS-485)
- Network: 8-pin RJ-45

LED Indicators

- Number of LEDs: 5
 - Power on
 - Network linked
 - Network activity

Physical

- Operating Temperature: -40°F to 150°F (-40°C to 65.5°C)
- Size:
 - 1.41in (35.7mm) wide
 - 3.88in (98.5mm) tall
 - 3.1in (78mm) deep (not including connector)
- Weight: 4.8 oz (136 g)
- Enclosure Material: Lexan 940 Polycarbonate Plastic
- Enclosure Flame Rating: UL94 V0

Protocols

- HTTP, HTTPS, SSL, SMTP, Modbus TCP/IP, Remote Services server and client

Logging

- Up to 5 log files
- Stored in Nonvolatile Flash or external USB thumb drive
- 20Mbytes max each log file (internal)
- Unlimited data storage with external USB thumb drive
- Data wraps-around when full

Password Settings

- Password protection on setup page: Yes
- Password protection on control page: Optional
- Password Encoding: Base 64
- Max Password Length: 20 Characters

Electromagnetic Compliance

- IEC CISPR 22, CISPR 24
- FCC 47CFR15 (Class B)
- EN55024 ITE Immunity (2010)
- EN55022 Emissions (2010)

Product Safety Compliance

- UL 61010-1 (Electrical Equipment for Measurement, Control, and Laboratory Use)



PRODUCT OVERVIEW



The X-11s™ 2-relay expansion module is used in conjunction with the X-600M™ controller.

The X-11s has two high-current relays. Both relays have Form-C contacts (SPDT). A rugged, high-current connector provides connections to the relays. One or more X-11s expansion modules can be connected to a X-600M control module with a ribbon cable. The ribbon cable provides both power and communications to the expansion modules.

The X-600M is a multifunction web-enabled industrial I/O controller. It performs control, logic, and monitoring functions similar to that of a Programmable Logic Controller (PLC). However, unlike a PLC, the X-600M is designed for web-based applications from

the ground up. No add-on software or hardware is required.

The X-600M can be fully configured, programmed and tested using its built-in web server. The web setup pages are intuitive and easy to use and do not require special programming skills.

The X-600M together with expansion modules such as the X-11s provide an easy, flexible and reliable way to monitor and control systems and devices over a network. The X-11s is suitable for use with loads which require line voltages and high current such as pumps, motors, lights and heaters.

Features:

- Two, large SPDT relays (277VAC and 20 Amps) independently controlled
- Removable locking connector supports 24AWG to 10AWG
- Two relay LEDs
- Removable terminal connector
- Powered through expansion bus
- Great for applications including:
 - Lighting control
 - Door locks
 - Remote gate control
 - Motor control
 - Pumps
 - and much more...

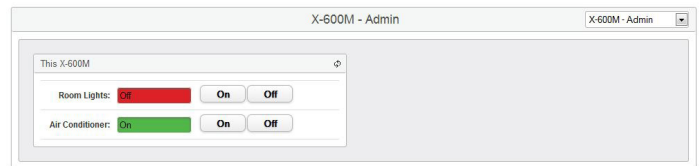

View X-11s components on the X-600M's Dashboard

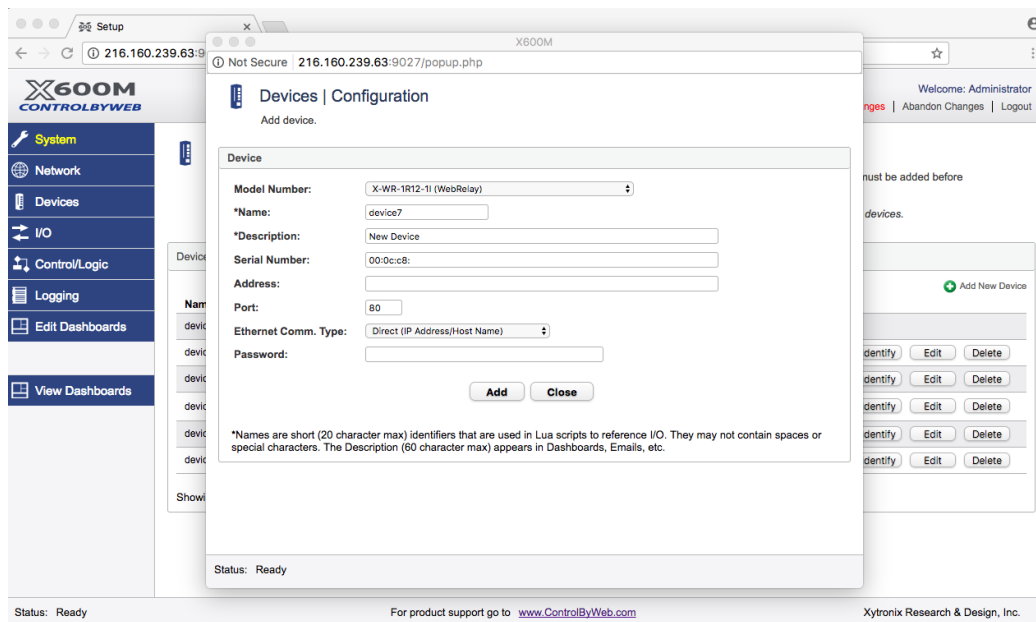

Adding the X-11s on the X-600M

APPLICATIONS & SPECS

Expansion Modules With The X-600M Controller

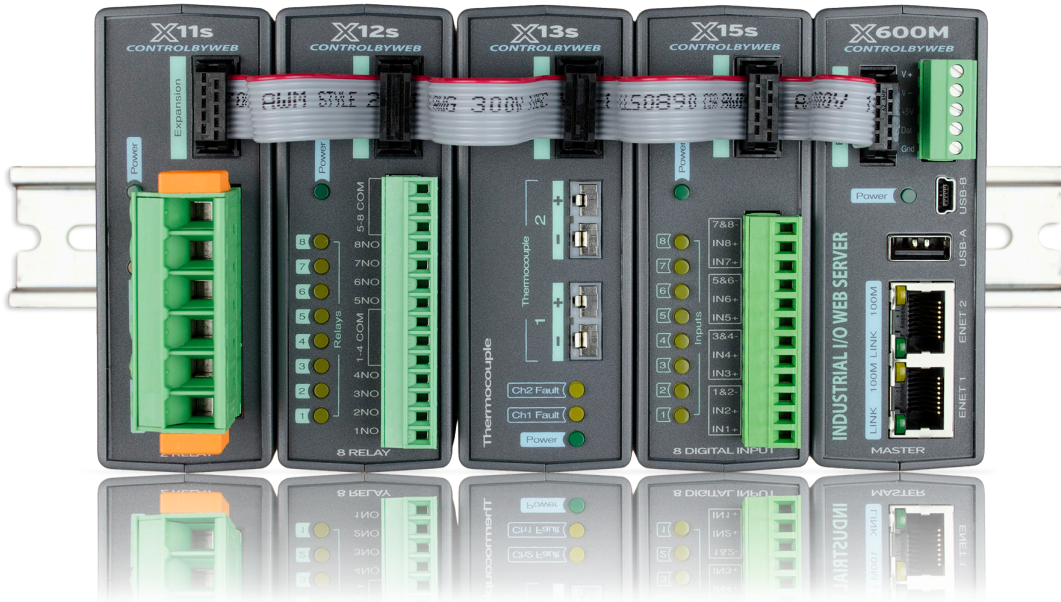

Applications

- ✓ Lighting Control
- ✓ Door Locks
- ✓ Remote Gate Control
- ✓ Motor Control
- ✓ Pumps
- ✓ More...

Models:

- X-11s

Power Requirements

- Voltage: 9-28 VDC (supplied via the X-600M controller, 24V recommended)
- Max Current: See table below for typical values at 25°C.

Power Supply	All Relays OFF	All Relays ON
9 VDC	15 mA	260 mA
12 VDC	12 mA	196 mA
24 VDC	7 mA	105 mA

Relay Contacts

- Number of Relays: 2
- Max Voltage: 277VAC, 110VDC (NO contact), 30VDC (NC contact)
- Max Current: 20A
- Contact Type: SPDT (Form 1C)
- Load Type: General Purpose
- Contact Resistance: < 30 milliohms initial
- Contact Material: AgSnO2
- Electrical Life: 100K cycles (Typical)
- Mechanical Life: 10M cycles (Typical)
- Environmental Rating: Over voltage Category II, Pollution Degree 2
- Relay Modes: On/Off or Pulsed
- Pulse Timer Duration: 0.1 to 86,400 Seconds (1-day)

Connectors

- Relays: 6-Position, 7.62mm, Removable (with tool-free snap-lock latches)
- Expansion Connector: Ribbon cable, 10-conductor, polarized, 2x5-position, 0.100" pitch Provides power and communications for expansion modules (Communications: RS-485)

LED Indicators

- Number of LEDs: 3
 - Power on
 - Relay coil energized 1-2

Physical

- Size:
 - 1.41in (35.7mm) wide
 - 3.88in (98.5mm) tall
 - 3.1in (78mm) deep (not including connector)
- Weight: 4.8 oz (136 g)
- Enclosure Material: Lexan 940 Polycarbonate Plastic
- Enclosure Flame Rating: UL94 V0

Environmental

- Operating Temperature: -40°F to 150°F (-40°C to 65.5°C)
- Storage Temperature: -40°F to 185°F (-40°C to 85°C)
- Humidity: 5-95%, non-condensing
- Altitude: Up to 2,000m
- Indoor use or NEMA-4 protected location

Electromagnetic Compliance

- IEC CISPR 22, CISPR 24
- FCC 47CFR15 (Class B)
- EN55024 ITE Immunity (2010)
- EN55022 Emissions (2010)

Product Safety Compliance

- UL 61010-1 (Electrical Equipment for Measurement, Control, and Laboratory Use)



PROCESS CONTROL EQUIPMENT
E468316

PRODUCT OVERVIEW



The X-12s™ 8-Relay expansion module is used with the X-600M controller. The X-12s has eight relays, each with Form-A contacts (SPST). A removable terminal connector provides connections to the relays.

One or more X-12s expansion modules can be connected to a X-600M controller with a ribbon cable.

The ribbon cable provides both power and communications to the expansion modules.

The X-600M is a multifunction web-enabled industrial I/O controller. It performs control, logic, and monitoring functions similar to that of a Programmable Logic Controller (PLC). However, unlike a PLC, the X-600M is

designed for web-based applications from the ground up. No add-on software or hardware is required.

The X-600M can be fully configured, programmed and tested using its built-in web server. The web setup pages are intuitive and easy to use and do not require special programming skills.

The X-600M together with expansion modules such as the X-12s provide an easy, flexible and reliable way to monitor and control systems and devices over a network. The X-12s is suitable for use with moderate loads such as solenoid valves, alarms and indicator lights.

Features:

- Eight SPST relays (125VAC, 30VDC @ 2.5A) independently controlled
- Removable connector
- Eight relay LEDs
- Removable terminal connector
- Powered through expansion bus
- Great for moderate-load applications including:
 - Solenoid valves
 - Alarms
 - Indicator lights
 - and much more...

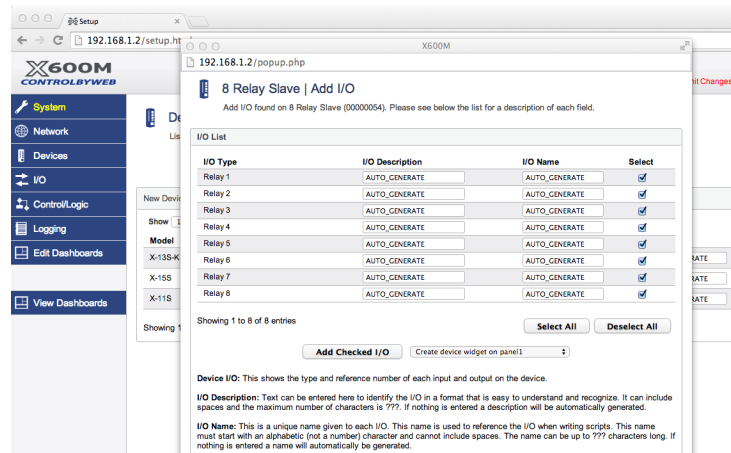

Adding the X-12s on the X-600M

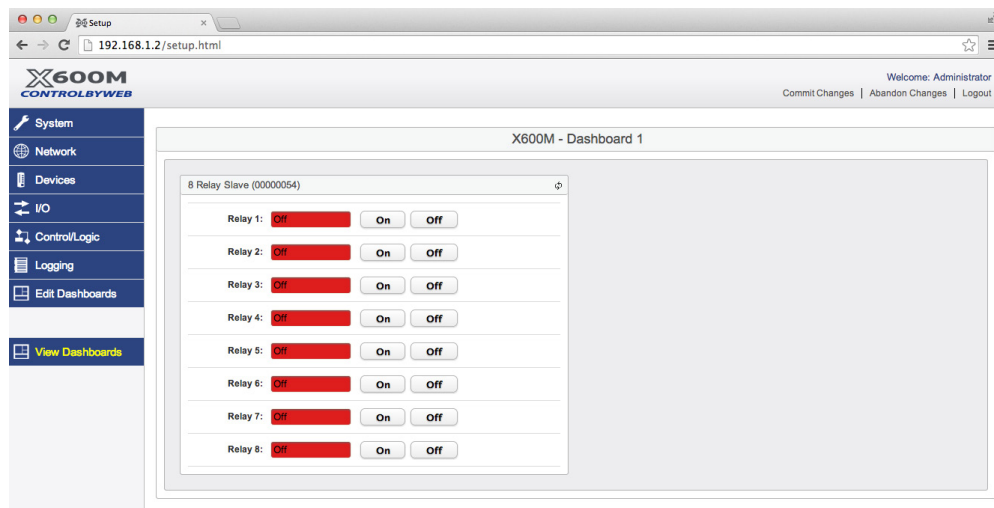

View X-12s components on the X-600M's Dashboard

APPLICATIONS & SPECS

Expansion Modules With The X-600M Controller



Applications

- ✓ Solenoid Valves
- ✓ Alarms
- ✓ Indicator Lights
- ✓ More...

Models:

- X-12s

Power Requirements

- Voltage: 9-28 VDC (supplied via the X-600M controller, 24V recommended)
- Max Current: See table below for typical values at 25°C.

Power Supply	All Relays OFF	All Relays ON
9 VDC	16 mA	344 mA
12 VDC	12 mA	258 mA
24 VDC	7 mA	133 mA

Relay Contacts

- Number of Relays: 8
- Max Voltage: 125VAC, 30VDC
- Max Current: 2.5A (total for each group of 4 relays with shared commons)
- Contact Type: SPST (Form 1A)
- Load Type: General Purpose
- Contact Resistance: < 100 milliohms initial
- Contact Material: AgSnO2
- Electrical Life: 100K operations (Min)
- Mechanical Life: 5M cycles (Min)
- Environmental Rating: Over voltage Category II, Pollution Degree 2
- Relay Modes: On/Off or Pulsed
- Pulse Timer Duration: 0.1 to 86,400 Seconds (1-day)

Connectors

- Relays: 14-Position, 3.81mm, Removable
- Expansion Connector: Ribbon cable, 10-conductor, polarized, 2x5-position, 0.100" pitch Provides power and communications for expansion modules (Communications: RS-485)

LED Indicators

- Number of LEDs: 9
 - Power on
 - Relay coil energized 1-8

Physical

- Size:
 - 1.41in (35.7mm) wide
 - 3.88in (98.5mm) tall
 - 3.1in (78mm) deep (not including connector)
- Weight: 4.8 oz (136 g)
- Enclosure Material: Lexan 940 Polycarbonate Plastic
- Enclosure Flame Rating: UL94 V0

Environmental

- Operating Temperature: -40°F to 150°F (-40°C to 65.5°C)
- Storage Temperature: -40°F to 185°F (-40°C to 85°C)
- Humidity: 5-95%, non-condensing
- Altitude: Up to 2,000m
- Indoor use or NEMA-4 protected location

Electromagnetic Compliance

- IEC CISPR 22, CISPR 24
- FCC 47CFR15 (Class B)
- EN55024 ITE Immunity (2010)
- EN55022 Emissions (2010)

Product Safety Compliance

- UL 61010-1 (Electrical Equipment for Measurement, Control, and Laboratory Use)



PROCESS CONTROL EQUIPMENT
E468316

PRODUCT OVERVIEW



The X-13s™ Thermocouple expansion module is used in conjunction with the X-600M™ controller. The X-13s is a 2-channel signal conditioner for Type-K thermocouples. One or more X-13s thermocouple expansion modules can be connected to a X-600M control module with a ribbon cable. The ribbon cable provides both power and communications to the module.

The X-600M is a multifunction web-enabled industrial I/O controller. It performs control, logic, and monitoring functions similar to that of a Programmable Logic Controller (PLC). However, unlike a PLC, the X-600M is designed for web-based applications from the ground up. No add-on software or hardware is required.

The X-600M can be fully configured, programmed and tested using its built-in web server. The web setup pages are intuitive and easy to use and do not require special programming skills.

The X-600M together with the X-13s provide an easy, flexible and reliable way to monitor temperature over a network. The X-13s is suitable for use with freezers, ovens, fermenters, generators – anywhere precision, rugged, temperature sensors are required.

Features:

- 2-Channel thermocouple inputs
- Type K Thermocouples
- Range -200°C to +1250°C
- Two “Open Thermocouple” Channel LEDs
- Powered through expansion bus
- Great for moderate-load applications including:
 - Freezers
 - Ovens
 - Fermenters
 - Generators
 - and much more...

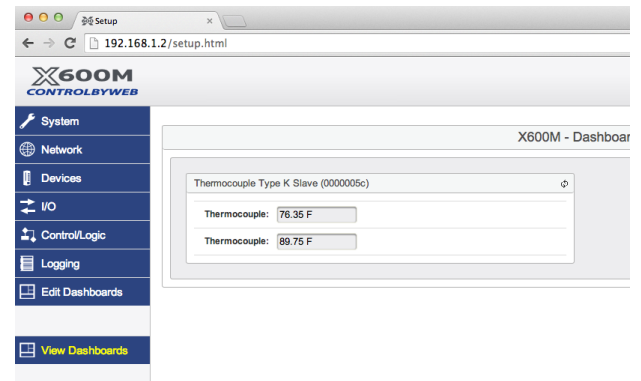

View X-13s components on the X-600M's Dashboard

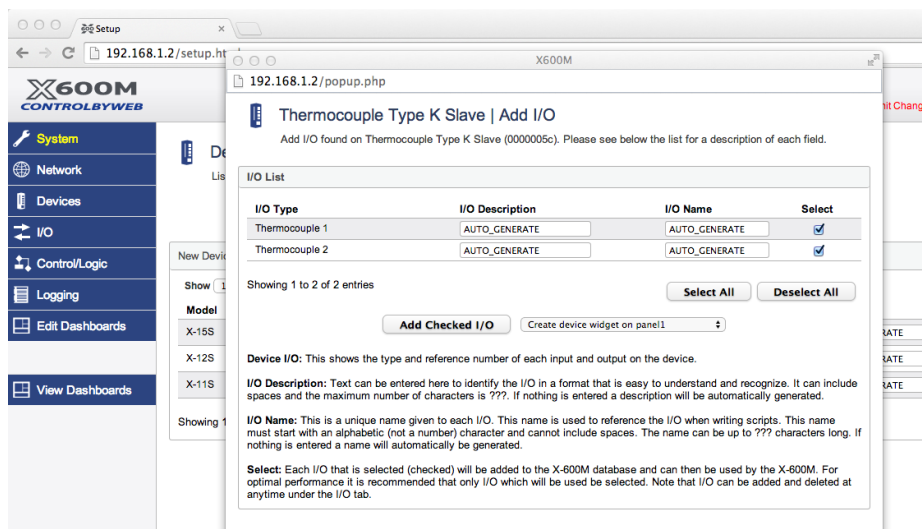

Adding the X-13s on the X-600M

APPLICATIONS & SPECS

Expansion Modules With The X-600M Controller



Applications

- ✓ Freezers
- ✓ Ovens
- ✓ Fermenters
- ✓ Generators
- ✓ More...

Models:

- X-13s

Power Requirements

- Voltage: 9-28 VDC (supplied via the X-600M controller, 24V recommended)
- Max Current: See table below for typical values at 25°C.

Power	Thermocouple Open	Thermocouple Good
9 VDC	49 mA	17 mA
12 VDC	37 mA	13 mA
24 VDC	20 mA	8 mA

Thermocouples

- Number of channels: 2 Channels
- Thermocouple: Type-K
- Linear Range: -200°C to 1250°C
- Operating Ambient: -40°C to 85°C (internal cold junction compensation)
- Resolution: 0.027°C
- Drift: 4ppm/°C typical, 15ppm/°C max
- Type: Inputs are not isolated, only use ungrounded thermocouples
- Input Current: Differential, ±165nA max
- Error Detection Detects sensor breakage or disconnection of lead wire

Connectors

- Type: Miniature size, Omega PCC-SMP Series, Type-K
- Mating Connector: Miniature size, SMP
- Expansion Connector: Ribbon cable, 10-conductor, polarized, 2x5-position, 0.100" pitch Provides power and communications for expansion modules (Communications: RS-485)

LED Indicators

- Number of LEDs: 3
 - Power on
 - "Open Thermocouple (Channels 1-2)

Physical

- Size:
 - 1.41in (35.7mm) wide
 - 3.88in (98.5mm) tall
 - 3.1in (78mm) deep (not including connector)
- Weight: 4.8 oz (136 g)
- Enclosure Material: Lexan 940 Polycarbonate Plastic
- Enclosure Flame Rating: UL94 V0

Environmental

- Operating Temperature: -40°F to 150°F (-40°C to 65.5°C)
- Storage Temperature: -40°F to 185°F (-40°C to 85°C)
- Humidity: 5-95%, non-condensing
- Altitude: Up to 2,000m
- Indoor use or NEMA-4 protected location

Electromagnetic Compliance

- IEC CISPR 22, CISPR 24
- FCC 47CFR15 (Class B)
- EN55024 ITE Immunity (2010)
- EN55022 Emissions (2010)

Product Safety Compliance

- UL 61010-1 (Electrical Equipment for Measurement, Control, and Laboratory Use)



PROCESS CONTROL EQUIPMENT
E468316

PRODUCT OVERVIEW

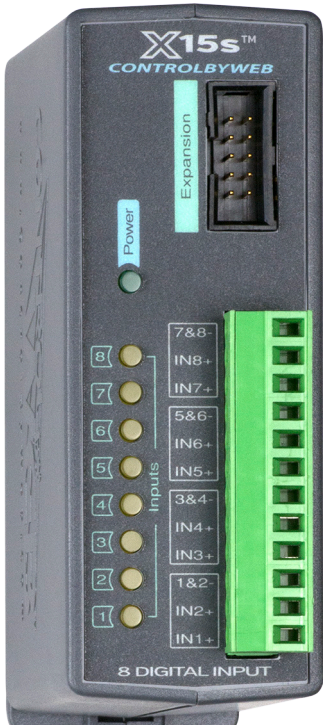

The X-15s™ expansion module is used in conjunction with the X-600M controller. The X-15s has eight optically-isolated digital inputs. The isolated inputs are suitable for use in industrial environments and allow the grounding system of the monitored equipment and the low voltage circuits of the X-15s to be electrically separate.

Internally the X-15s has a co-processor which provides enhanced features including: pulse counting, pulse duration, accumulated pulse time and frequency measurements. All 8-inputs have separate measurements. Programmable de-bounce timers allow glitches and short pulses to be filtered out.

One or more X-15s 8-input expansion modules can be connected to a X-600M control module with a ribbon cable. The

ribbon cable provides both power and communications.

The X-600M is a multifunction web-enabled industrial I/O controller. It performs control, logic, and monitoring functions similar to that of a Programmable Logic Controller (PLC). However, unlike a PLC, the X-600M is designed for web-based applications from the ground up. No add-on software or hardware is required.

The X-600M can be fully configured, programmed and tested using its built-in web server. The web setup pages are intuitive and easy to use and do not require special programming skills.

The X-600M together with the X-15s provide an easy, flexible and reliable way to monitor the state of sensors and devices over a network. The X-15s is suitable for use with security systems, freezer doors, light switches and water meters – anywhere where remote sensing is required.

The X-15s' inputs can be used to trigger email alerts based on a single change of state or after a number of state changes. The inputs can also be used as counters, or can be used to control the relay contacts of other ControlByWeb™ products (such as WebRelay™) that are located at a remote location.

Features:

- 8 Optically-isolated digital inputs
- Digital input functions:
 - Pulse
 - Frequency
 - Timer
 - Count
- Eight LEDs for inputs 1-8
- Removable terminal connector
- Powered through expansion bus
- Great for monitoring applications including:
 - Button/Switch Inputs
 - Security Sensors
 - Flow Meters
 - Machine Status
 - and much more...

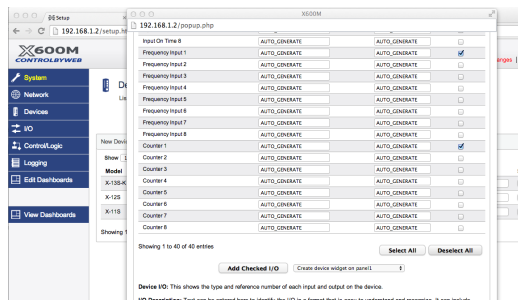
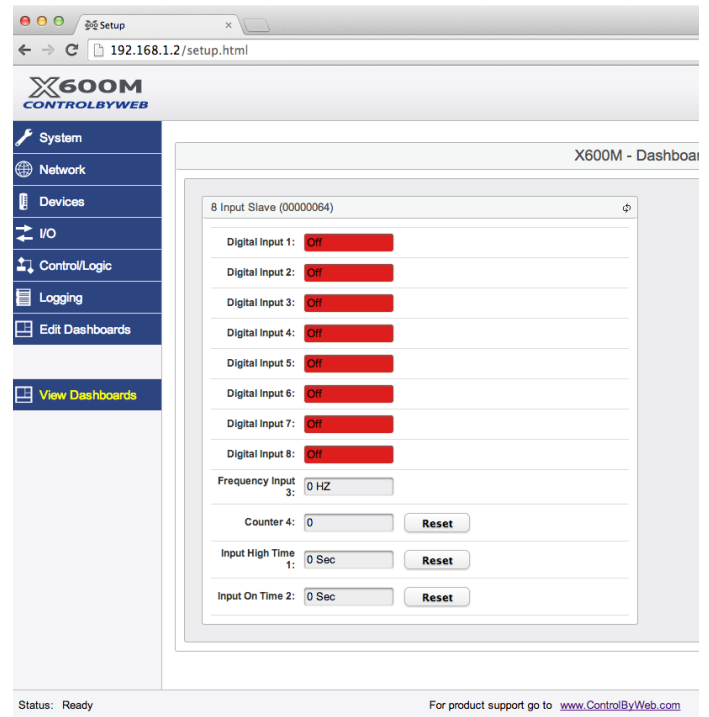

Adding the X-15s on the X-600M

View X-15s components on the X-600M's Dashboard

APPLICATIONS & SPECS

Expansion Modules With The X-600M Controller



Applications

- ✓ Security Sensors
- ✓ Flow Meters
- ✓ Machine Status
- ✓ More...

Models:

- X-15s

Power Requirements

- Voltage: 9-28 VDC (supplied via the X-600M controller, 24V recommended)
- Max Current: See table below for typical values at 25°C.

Power	Opto-couplers OFF	Opto-couplers ON
9 VDC	17 mA	88 mA
12 VDC	13 mA	66 mA
24 VDC	8 mA	36 mA

Digital Inputs

- Number of Inputs: 8
- Type: Optically-Isolated
- Voltage Range: 3-26VDC
- Current: 0.6mA @ 3V, 8.2mA @ 26V
- Minimum Hold Time: 2.5mS
- Input Isolation: 1500V
- Input Functions: Monitor State, Control Relays, Control Remote Relays, Count, Frequency, High Time, ON Time
- Maximum Count: 32-bit
- Max Count Rate: 200Hz
- Edge Trigger: Rising, Falling or Both
- High Time: Pulse width (4,194,304 seconds max)
- On Time: Accumulated time an input is asserted (4,194,304 seconds max)
- Frequency: 1Hz min, 200 Hz max

Connectors

- Inputs: 12-Position, 3.81mm, Removable
- Expansion Connector: Ribbon cable, 10-conductor, polarized, 2x5-position, 0.100" pitch Provides power and communications for expansion modules (Communications: RS-485)

LED Indicators

- Number of LEDs: 9
 - Power on
 - Digital Inputs 1-8

Physical

- Size:
 - 1.41in (35.7mm) wide
 - 3.88in (98.5mm) tall
 - 3.1in (78mm) deep (not including connector)
- Weight: 4.8 oz (136 g)
- Enclosure Material: Lexan 940 Polycarbonate Plastic
- Enclosure Flame Rating: UL94 V0

Environmental

- Operating Temperature: -40°F to 150°F (-40°C to 65.5°C)
- Storage Temperature: -40°F to 185°F (-40°C to 85°C)
- Humidity: 5-95%, non-condensing
- Altitude: Up to 2,000m
- Indoor use or NEMA-4 protected location

Electromagnetic Compliance

- IEC CISPR 22, CISPR 24
- FCC 47CFR15 (Class B)
- EN55024 ITE Immunity (2010)
- EN55022 Emissions (2010)

Product Safety Compliance

- UL 61010-1 (Electrical Equipment for Measurement, Control, and Laboratory Use)



PRODUCT OVERVIEW



The X-16s™ expansion module is used in conjunction with the X-600M™ controller. The X-16s has eight, 0-5V, analog inputs. The X-16s employs a 24-bit A/D converter and can make both single or differential voltage measurements. A 5.0V reference output can be used to power potentiometers or other resistance sensing sensors.

The X-16s is ideal for measuring precision analog voltages in industrial environments. One or more X-16s expansion modules can be connected to a X-600M control module with a ribbon cable. The ribbon cable provides both power and communications.

The X-600M is a multifunction web-enabled industrial I/O controller. It performs control, logic, and monitoring functions similar to that of a

Programmable Logic Controller (PLC). However, unlike a PLC, the X-600M is designed for web-based applications from the ground up. No add-on software or hardware is required.

The X-600M can be fully configured, programmed and tested using its built-in web server. The web setup pages are intuitive and easy to use and do not require special programming skills.

The X-600M together with the X-16s provide an easy, flexible and reliable way to monitor sensors and devices over a network. The X-16s is suitable for use with pressure sensors, flow meters, current transducers and position sensors – anywhere where precision analog voltage sensing is required.

The X-16s' inputs can be used to trigger email alerts based on a voltage level and can be used to control the relay contacts of other ControlByWeb™ products (such as WebRelay™) that are located at a remote location.

Features:

- Eight, 0-5V precision analog inputs
- Removable terminal connector
- Powered through expansion bus
- Great for monitoring applications including:
 - Temperature
 - Electrical Current
 - Pressure
 - Fluid Levels
 - and much more...

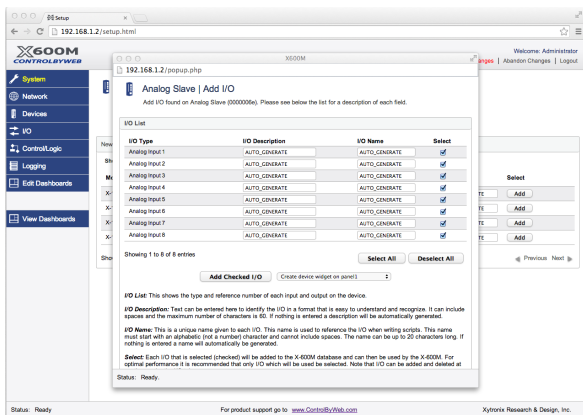
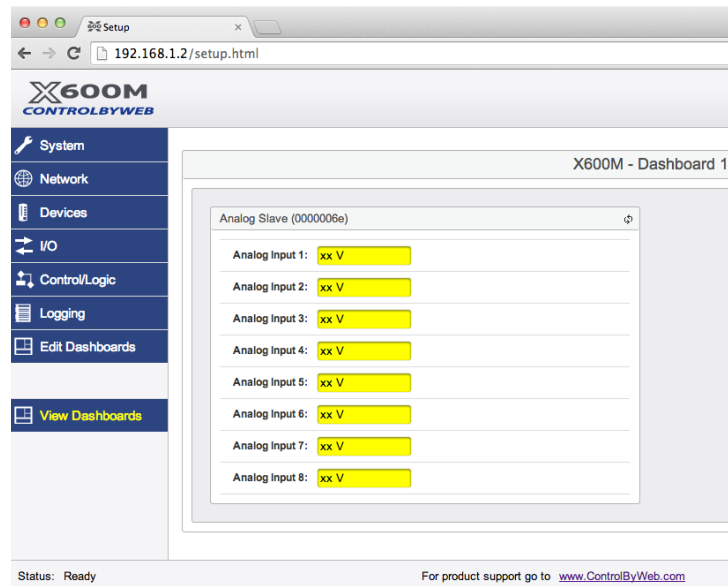

Adding the X-16s on the X-600M

View X-16s components on the X-600M's Dashboard

APPLICATIONS & SPECS

Expansion Modules With The X-600M Controller



Applications

- ✓ Temperature
- ✓ Electrical Current
- ✓ Pressure
- ✓ Fluid Levels
- ✓ More...

Models:

- X-16s

Power Requirements

- Voltage: 9-28 VDC (supplied via the X-600M controller, 24V recommended)
- Max Current: See table below for typical values at 25°C.

Power	Current
9 VDC	40 mA
12 VDC	30 mA
24 VDC	18 mA

Analog Inputs

- Number of Inputs: 8
- Type: 8 single-ended, 4-differential, or a combination
- Input Range: -0.1V (min), 5.1V (max), all channels
- **Note that inputs have high impedance so input range can easily be adjusted using external resistors. Example: 0 to 10 Volt or 4-20mA
- Resolution: 10µV (24 bit ΣΔ ADC)
- Reference: 5.00V, 0.04%, 3ppm/C, 50mA Max

Connectors

- Inputs: 14-Position, 3.81mm, Removable
- Expansion Connector: Ribbon cable, 10-conductor, polarized, 2x5-position, 0.100" pitch Provides power and communications for expansion modules (Communications: RS-485)

LED Indicators

- Number of LEDs: 1
 - Power on

Physical

- Size:
 - 1.41in (35.7mm) wide
 - 3.88in (98.5mm) tall
 - 3.1in (78mm) deep (not including connector)
- Weight: 4.8 oz (136 g)
- Enclosure Material: Lexan 940 Polycarbonate Plastic
- Enclosure Flame Rating: UL94 V0

Environmental

- Operating Temperature: -40°F to 150°F (-40°C to 65.5°C)
- Storage Temperature: -40°F to 185°F (-40°C to 85°C)
- Humidity: 5-95%, non-condensing
- Altitude: Up to 2,000m
- Indoor use or NEMA-4 protected location

Electromagnetic Compliance

- IEC CISPR 22, CISPR 24
- FCC 47CFR15 (Class B)
- EN55024 ITE Immunity (2010)
- EN55022 Emissions (2010)

Product Safety Compliance

- UL 61010-1 (Electrical Equipment for Measurement, Control, and Laboratory Use)



PRODUCT OVERVIEW



The X-17s™ expansion module is used in conjunction with the X-600M controller. The X-17s is a multi-function module with four relays and four optically-isolated digital inputs. One or more X-17s expansion modules can be connected to a X-600M control module with a ribbon cable which provides both power and communications.

The four relays have Form-A contacts (SPST) and can be used to control moderate loads such as solenoid valves, alarms, and indicator lights.

The isolated inputs are suitable for use in industrial environments and allow the grounding system of the monitored equipment and the low voltage circuits of the X-17s to be electrically separate. Internally the X-17s has a co-processor which provides enhanced features

including: pulse counting, pulse duration, accumulated pulse time, and frequency measurements. All four inputs have separate measurements. Programmable de-bounce timers allow glitches and short pulses to be filtered out.

The X-600M is a multifunction web-enabled industrial I/O controller. It performs control, logic, and monitoring functions similar to that of a Programmable Logic Controller (PLC). However, unlike a PLC, the X-600M is designed for web-based applications from the ground up. No add-on software or hardware is required. The X-600M can be fully configured, programmed, and tested using its built-in web server. The web setup pages are intuitive and easy to use and do not require special programming skills.

The X-600M together with the X-17s provides an easy, flexible, and reliable way to monitor sensors and control devices over a network. The X-17s is suitable for use with security systems, freezer doors, light switches, and water meters, as well as with moderate loads such as solenoid valves, alarms, and indicator lights.

Features:

- Four isolated relays (SPST)
- Relay Functions:
 - On
 - Off
 - Pulse
- Four optically-isolated digital inputs (common negative)
- Input Functions:
 - On/Off Status
 - Pulse Count
 - Pulse Duration
- Accumulated Pulse Time
- Frequency
- Powered through expansion bus - no separate power supply connections are required
- Eight LEDs for inputs and outputs
- Removable terminal connector

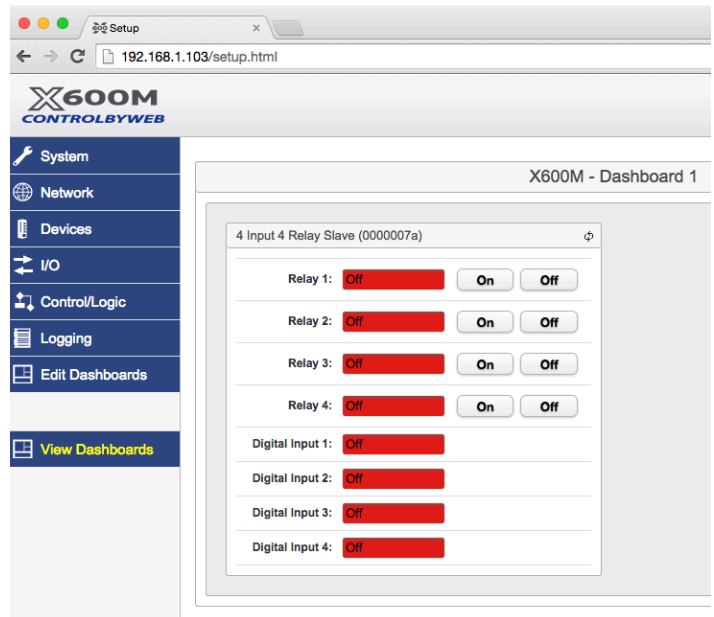

View X-17s components on the X-600M's Dashboard

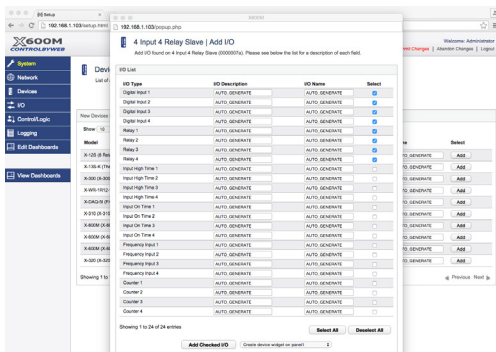

Adding the X-17s on the X-600M

APPLICATIONS & SPECS

Expansion Modules With The X-600M Controller



Applications

- ✓ Security Systems
- ✓ Freezer Doors
- ✓ Light Switches
- ✓ Water meters
- ✓ More

Models:

- X-17s

Power Requirements

- Voltage: 9-28 VDC (supplied via the X-600M controller, 24V recommended)
- Max Current: See table below for typical values at 25°C.

Power	All Opto-couplers & Relays OFF	All Opto-couplers & Relays ON
9 VDC	18 mA	224 mA
12 VDC	14 mA	165 mA
24 VDC	8 mA	86 mA

Relay Contacts

- Number of Relays: 4
- Max Voltage: 125VAC, 30VDC
- Max Current: 2.5A
- Contact Type: SPST (Form 1A)
- Load Type: General purpose
- Contact Resistance: < 100 milliohms initial
- Contact Material: AgSnO2
- Electrical Life: 100K operations (Min)
- Mechanical Life: 5M cycles (Min)
- Environmental Rating: Over voltage Category II, Pollution Degree 2
- Relay Modes: On/Off or Pulsed
- Pulse Timer Duration: 0.1 to 86,400 Seconds (1-day)

Digital Inputs

- Number of Inputs: 4
- Type: Optically-Isolated
- Voltage Range: 3-26VDC
- Current: 0.6mA @ 3V, 8.2mA @ 26V
- Minimum Hold Time: 2.5mS
- Input Isolation: 1500V
- Input Functions: Monitor State, Control Relays, Control Remote Relays, Count, Frequency, High Time, ON Time
- Maximum Count: 32-bit
- Max Count Rate: 200Hz
- Edge Trigger: Rising, Falling or Both
- High Time: Pulse width (4,194,304 seconds max)
- On Time: Accumulated time an input is asserted (4,194,304 seconds max)
- Frequency: 1 Hz min, 200 Hz max

Connectors

- Relays & Inputs: 14-Position, 3.81mm, Removable
- Expansion Connector: Ribbon cable, 10-conductor, polarized, 2x5-position, 0.100" pitch Provides power and communications for expansion modules (Communications: RS-485)

LED Indicators

- Number of LEDs: 9
 - Power on
 - Relay coil energized 1-4
 - Digital Inputs 1-4

Physical

- Size:
 - 1.41 in (35.7mm) wide
 - 3.88 in (98.5mm) tall
 - 3.1 in (78mm) deep (not including connector)
- Weight: 4.8 oz (136 g)
- Enclosure Material: Lexan 940 Polycarbonate Plastic
- Enclosure Flame Rating: UL94 V0

Environmental

- Operating Temperature: -40°F to 150°F (-40°C to 65.5°C)
- Storage Temperature: -40°F to 185°F (-40°C to 85°C)
- Humidity: 5-95%, non-condensing
- Altitude: Up to 2,000m
- Indoor use or NEMA-4 protected location

Electromagnetic Compliance

- IEC CISPR 22, CISPR 24
- FCC 47CFR15 (Class B)
- EN55024 ITE Immunity (2010)
- EN55022 Emissions (2010)

Product Safety Compliance

- IEC 61010-1



PRODUCT OVERVIEW



The X-18s™ expansion module is used with the X-600M controller. The X-18s has ten, high-current relays, each with Form-C contacts (SPDT).

Wiring connections are made directly to the relays using 1/4" tab terminals located on top of the relays.

This module is suitable for use with loads which require line voltages and high currents such as pumps, motors, lights and heaters. Attach multiple X-18s modules or a combination of expansion modules to the X-600M for an I/O combination that is tailored to your specific needs.

Features:

- 10 Isolated relays (SPDT)
- Relay Functions:
 - On
 - Off
 - Pulse
- Relay Connectors: 1/4 inch tab connectors
- Great for heavy-load applications including:
 - Motors
 - Solenoid valves
 - Lights
 - and much more...
- 11 LEDs for relays and power
- Power Supply: 9-28 VDC (24V recommended)

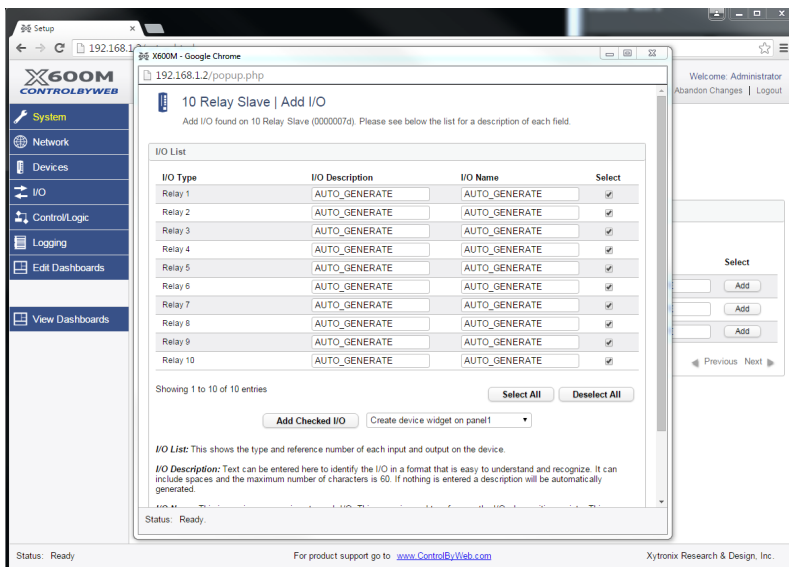

Adding the X-18s on the X-600M

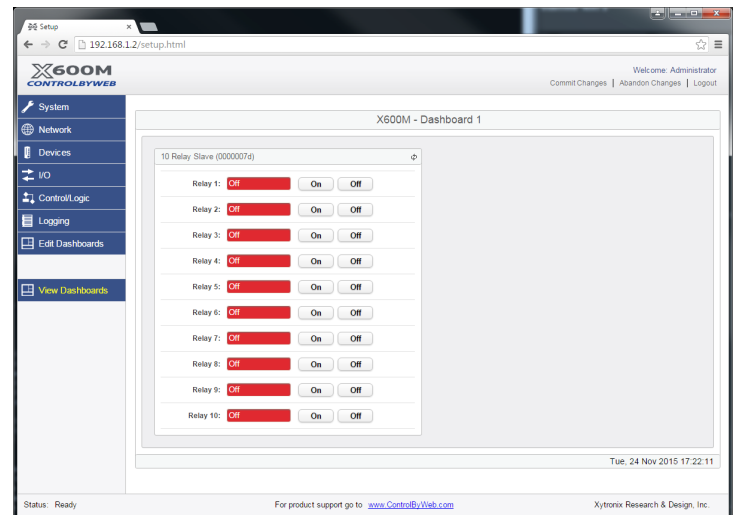

View X-18s components on the X-600M's Dashboard

APPLICATIONS & SPECS

High-Voltage Light Controller

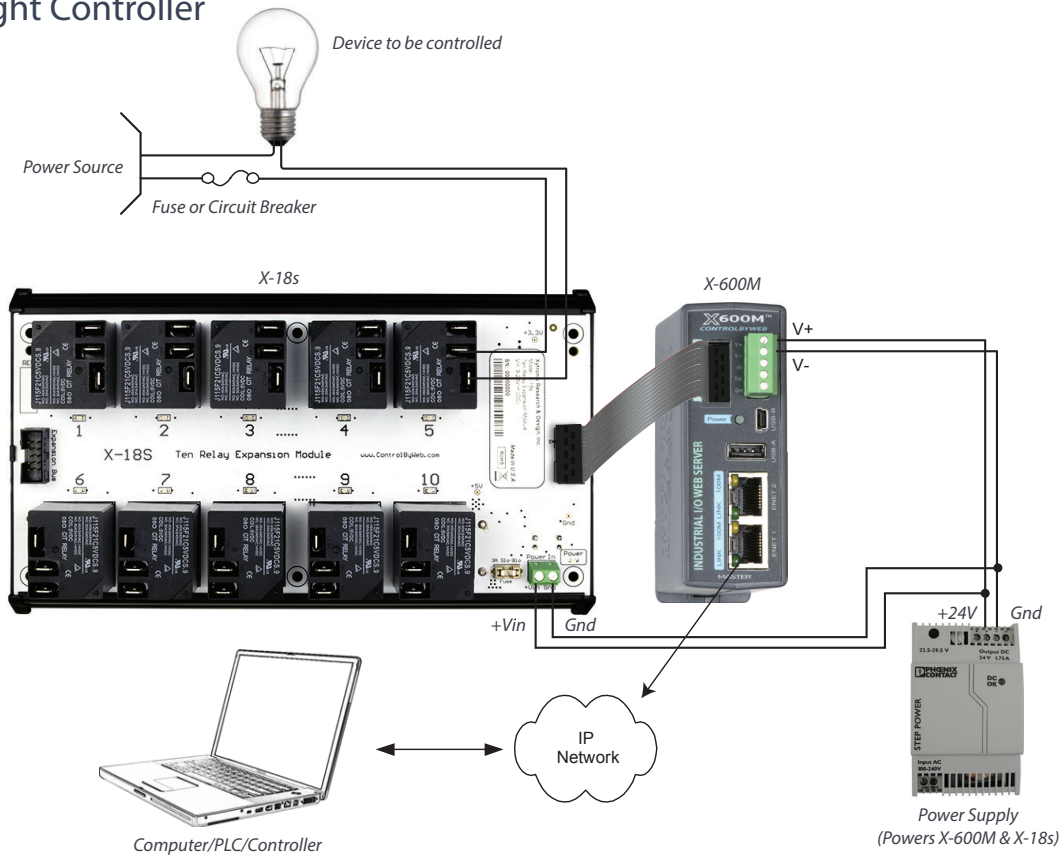

Models:

- X-18s

Power Requirements

- Voltage: 9-28 VDC (24V recommended)
- Max Current: See table below for typical values at 25°C.

Power Supply	All Relays OFF	All Relays ON
9VDC	18 mA	1200 mA
12 VDC	14 mA	880 mA
24 VDC	11 mA	450 mA

Relay Contacts

- Number of Relays: 10
- Max Voltage: 277VAC, 30VDC
- Max Current: 30A
- Contact Type: SPDT
- Load Type: General Purpose
- Contact Resistance: < 30 milliohms initial
- Contact Material: AgSnO2
- Electrical Life: 100K cycles (Typical)
- Mechanical Life: 10M cycles (Typical)
- Environmental Rating: Over voltage Category II, Pollution Degree 2
- Relay Modes: ON/OFF or Pulse
- Pulse Timer Duration: 0.1 to 86,400 Seconds (1-day)

Connectors

- Expansion Connector: Ribbon cable, 2x5-position, polarized 0.100" pitch
- Relays: 1/4" tab connectors

LED Indicators

- Number of LEDs: 11
 - Power on
 - Relays 1-10

Physical

- Size:
 - 8.60in (218.44mm) wide
 - 4.95in (125.73mm) tall
 - 2.46in (62.48mm) deep
- Weight: 20 oz (566 g)
- Enclosure Material: PVC
- Enclosure Flame Rating: UL94 V1

Environmental

- Operating Temperature: -40°F to 150°F (-40°C to 65.5°C)
- Storage Temperature: -40°F to 185°F (-40°C to 85°C)
- Humidity: 5-95%, non-condensing
- Altitude: Up to 2,000m
- Indoor use or NEMA-4 protected location

Electromagnetic Compliance

- IEC CISPR 22, CISPR 24
- FCC 47CFR15 (Class B)
- EN55024 ITE Immunity (2010)
- EN55022 Emissions (2010)

Product Safety Compliance

- IEC 61010-1



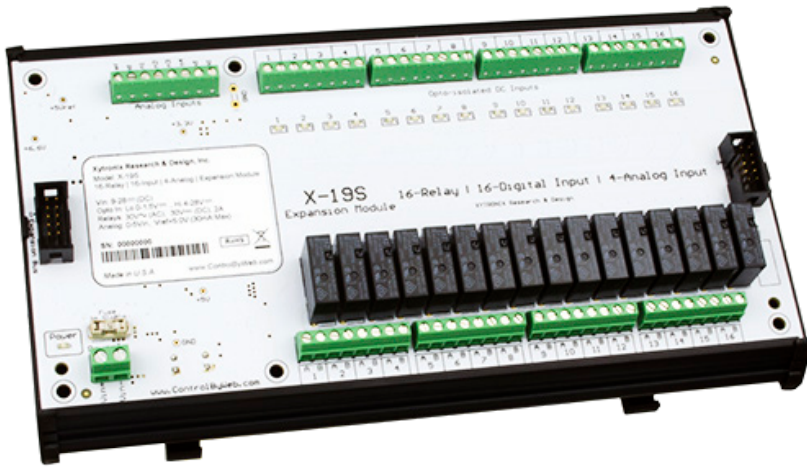

Features:

- 16 isolated relays SPST
- Relay functions: ON/OFF or Pulsed
 - Great for moderate-load applications including:
 - Solenoid valves
 - Lights
 - and much more moderate load applications
- PCB terminal block, screw connection, 3.81mm pitch
- 16 optically-isolated digital inputs
- Digital input functions:
 - Monitor State
 - Control Relays
 - Control Remote Relays
 - Count
- Input Debounce
- 4 analog inputs
- 33 LEDs for outputs and power
- Power Supply: 9-28 VDC (24V recommended)

The X-19s™ expansion module is used with the X-600M controller. The X-19s has 16 relays, 16 optically-isolated digital inputs, and 4 analog inputs. Screw terminal strips provide connections to the relays and inputs.

The X-19s is suitable for use in many applications from security systems to industrial controls where a high I/O count is required. It can be used to monitor freezer doors, light switches, and pulsed flow meters as well as control moderate loads such as solenoid valves, and lights.

Since the X-19s functions as a slave device to the X-600M, the advanced features of the X-600M can be utilized with this module. For example scheduling, remote relay control, logging, counting, email alerts based upon single input state change or multiple input state changes, analog slope and offset calculations, and many other features are available.

Attach multiple X-19s modules or a combination of expansion modules to the X-600M for an I/O combination that is tailored to your specific needs.

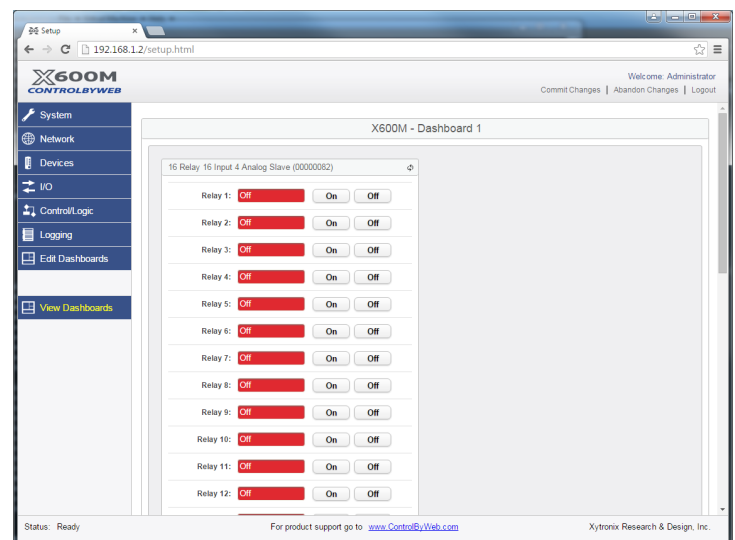
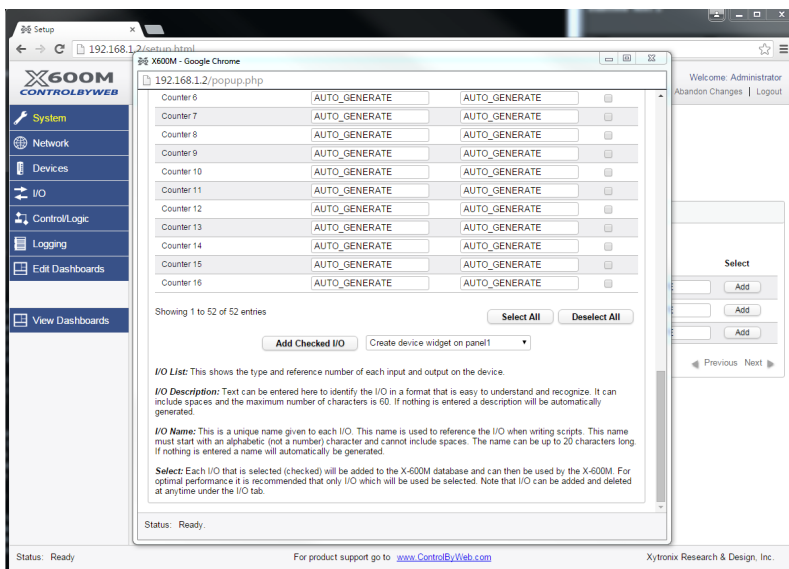

View X-19s components on the X-600M's Dashboard

Adding the X-19s on the X-600M

APPLICATIONS & SPECS

Shift Bell Controller

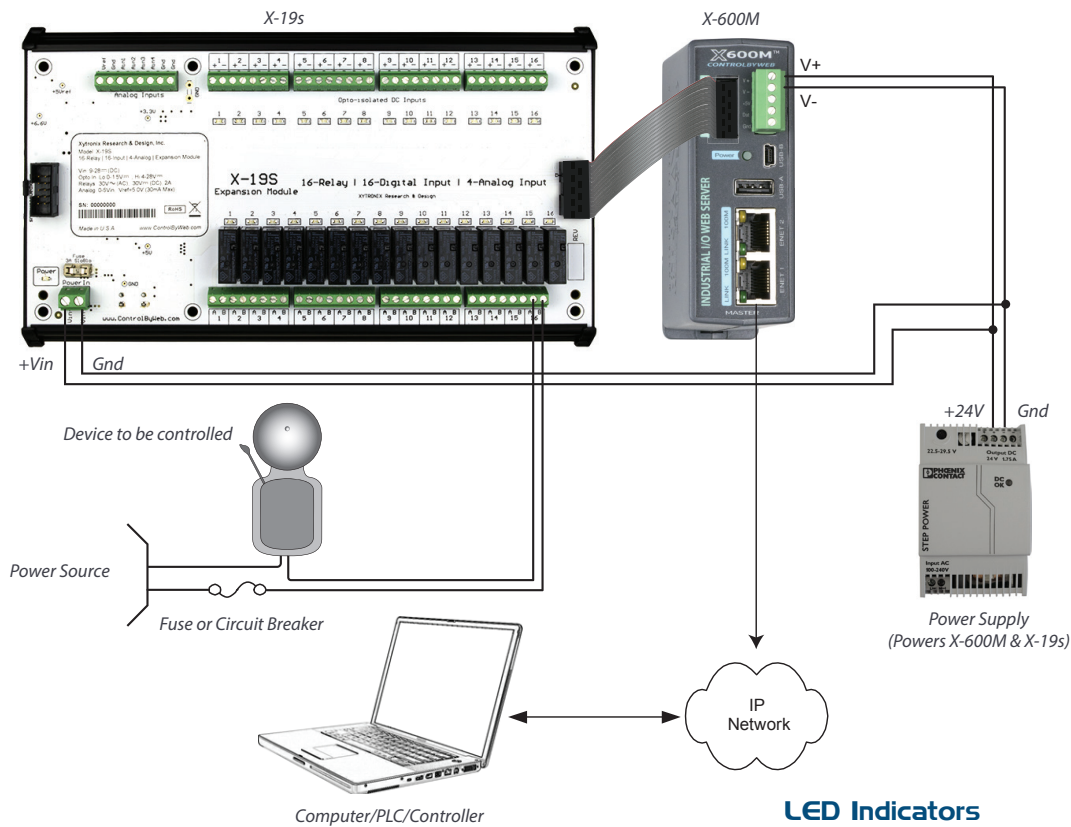

Models:

- X-19s

Power Requirements

- Voltage: 9-28 VDC (24V recommended)
- Max Current: See table below for typical values at 25°C.

Power Supply	All Relays OFF	All Relays ON
9 VDC	20 mA	650 mA
12 VDC	16 mA	490 mA
24 VDC	12 mA	250 mA

Relay Contacts

- Number of Relays: 16
- Max Voltage: 30VDC, 30VAC
- Max Current: 2A
- Contact Type: SPST
- Load Type: General Purpose
- Contact Resistance: < 100 milliohms initial
- Contact Material: AgSnO2
- Electrical Life: 100K operations (Min)
- Mechanical Life: 5M cycles (Min)
- Environmental Rating: Over voltage Category II, Pollution Degree 2
- Relay Modes: ON/OFF or Pulsed
- Pulse Timer Duration: 0.1 to 86,400 Seconds (1-day)

Digital Inputs

- Number of Inputs: 16
- Type: Optically-Isolated
- Voltage Range: 4-28VDC
- Vin Hi (Min): 4V
- Vin LO (Max): 1.5V
- Current: 950uA @ 4V, 8.5mA @ 26V
- Minimum Hold Time: 5ms
- Input Isolation: 1500V
- Input Functions: Asynchronous status of the digital inputs
- Number of Counter Inputs: 16
- Maximum Count: 32-bit
- Max Count Rate: 100 Hz
- Edge Trigger: Rising, Falling or Both

Analog Inputs

- Number of Inputs: 4
- Type: Single-ended channels
- Input Range: 0-5VDC
- Resolution: 12-bit
- Reference: 5.000V ±.04%, 3ppm, 30mA MAX

Connectors

- Expansion Connector: Ribbon cable, 2x5-position, polarized 0.100" pitch
- Relays & Inputs: PCB terminal block, screw connection, 3.81 mm pitch

LED Indicators

- Number of LEDs: 33
 - Power on
 - Relays 1-16
 - Digital Inputs 1-16

Physical

- Size:
 - 8.60in (218.44mm) wide
 - 4.95in (125.73mm) tall
 - 1.96in (49.78mm) deep
- Weight: 12 oz (342 g)
- Enclosure Material: PVC
- Enclosure Flame Rating: UL94 V1

Environmental

- Operating Temperature: -40°F to 150°F (-40°C to 65.5°C)
- Storage Temperature: -40°F to 185°F (-40°C to 85°C)
- Humidity: 5-95%, non-condensing
- Altitude: Up to 2,000m
- Indoor use or NEMA-4 protected location

Electromagnetic Compliance

- IEC CISPR 22, CISPR 24
- FCC 47CFR15 (Class B)
- EN55024 ITE Immunity (2010)
- EN55022 Emissions (2010)

Product Safety Compliance

- IEC 61010-1





The X-20s™ expansion module is used with the X-600M controller. The X-20s has six, high-current relays, each with Form-C contacts (SPDT) and six, optically-isolated digital inputs. A screw terminal strip provides high-current connections to the relays.

The X-20s is suitable for use with controlling relatively heavy loads such as motors, solenoid valves, and lights. Switches can be connected to the X-20s' digital inputs to locally control these loads. The digital inputs can also be used for other monitoring applications such as limit switches, security sensors, or light switches.

Since the X-20s functions as a slave device to the X-600M, the advanced features of the X-600M can be utilized with this module. For example scheduling, remote relay control, logging, counting, email alerts based upon single input state change or multiple input state changes, and many other features are available.

Attach multiple X-20s modules or a combination of expansion modules to the X-600M for an I/O combination that is tailored to your specific needs.

Features:

- 6 isolated relays SPDT
- Relay functions: ON/OFF or Pulse
- Great for heavy-load applications including:
 - Motors
 - Solenoid valves
 - Lights
 - and much more ...
- Thermoplastic, UL94V-0, 3-wall, 0.375" pitch
- 6 optically-isolated digital inputs
- Digital input functions:
 - Monitor State
 - Control Relays
 - Control Remote Relays
 - Count
 - Frequency
 - High Time
 - ON Time
- 13 LEDs for outputs, inputs, and power
- Power Supply: 9-28 VDC (24V recommended)

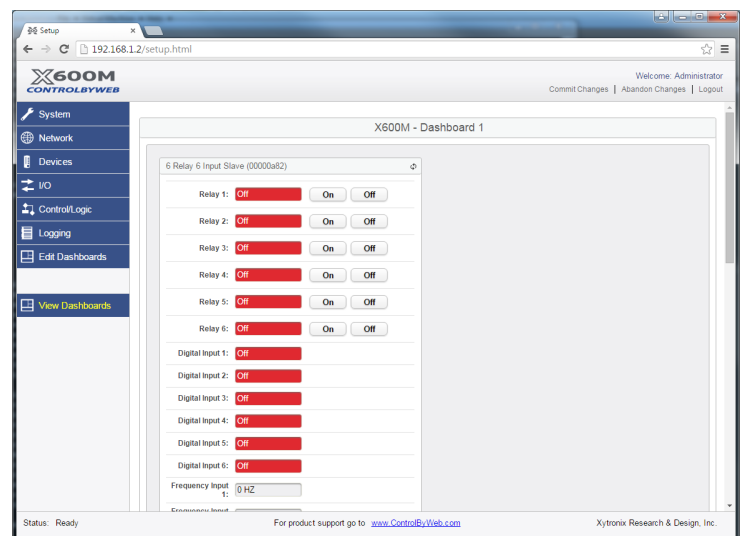
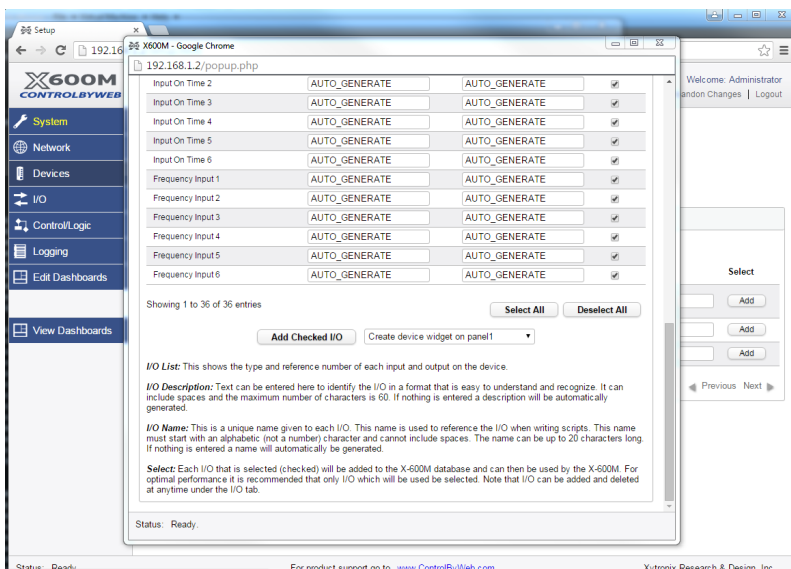

View X-20s components on the X-600M's Dashboard

Adding the X-20s on the X-600M

APPLICATIONS & SPECS

High-Voltage Light Controller

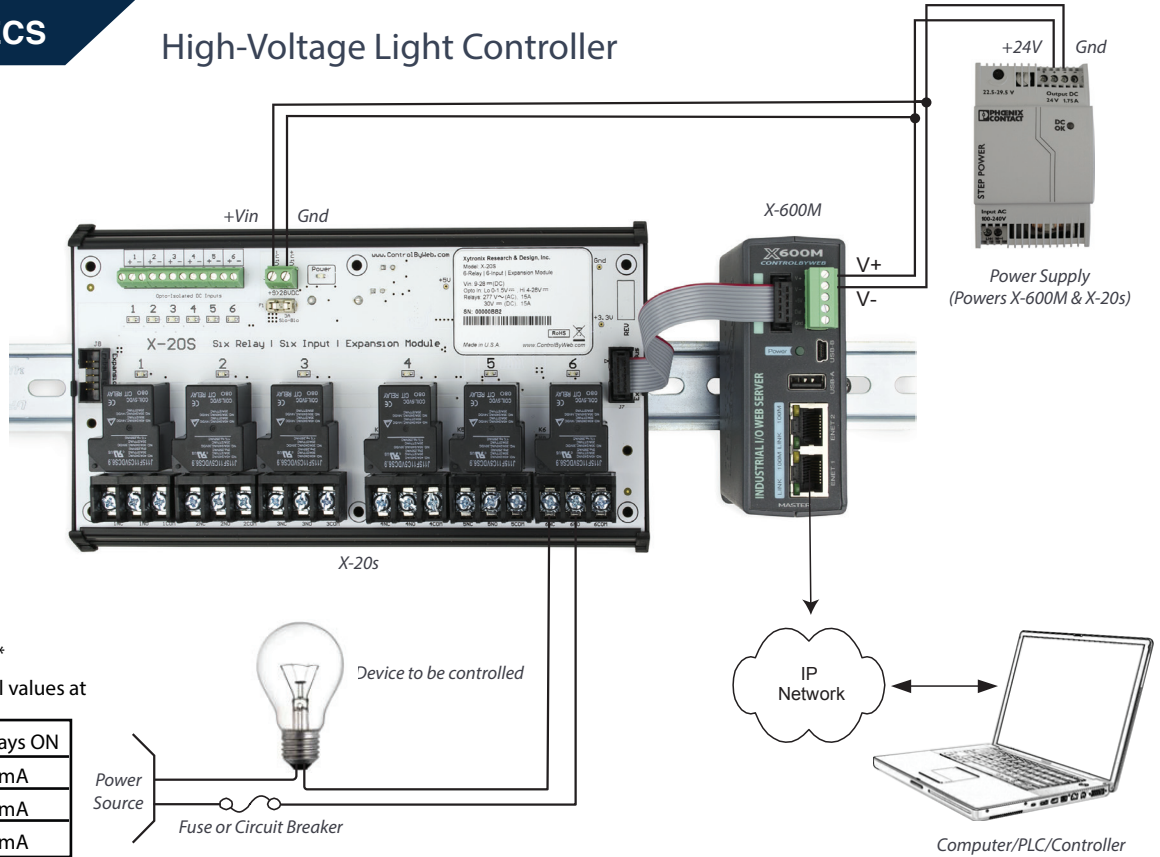

Models:

- X-20s

Power Requirements

- Voltage: 9-28 VDC (24V recommended)*
- Max Current: See table below for typical values at 25°C.

Power Supply	All Relays OFF	All Relays ON
9 VDC	20 mA	750 mA
12 VDC	16 mA	555 mA
24 VDC	12 mA	285 mA

Relay Contacts

- Number of Relays: 6
- Max Voltage: 277VAC, 30VDC
- Max Current: 15A
- Contact Type: SPDT
- Load Type: General Purpose
- Contact Resistance: < 30 milliohms initial
- Contact Material: AgSnO2
- Electrical Life: 100K cycles (Typical)
- Mechanical Life: 10M cycles (Typical)
- Environmental Rating: Over voltage Category II, Pollution Degree 2
- Relay Modes: ON/OFF or Pulse
- Pulse Timer Duration: 0.1 to 86,400 Seconds (1-day)

Digital Inputs

- Number of Inputs: 6
- Type: Optically-Isolated
- Voltage Range: 4-28VDC
- Vin Hi (Min): 4V
- Vin LO (Max): 1.5V
- Current: 950uA @ 4V, 8.5mA @ 26V
- Minimum Hold Time: 2.5ms
- Input Isolation: 1500V
- Input Functions: Asynchronous status of the digital inputs
- Number of Counter Inputs: 6
- Maximum Count: 32-bit
- Max Count Rate: 200 Hz

- Edge Trigger: Rising, Falling or Both
- Frequency: 1Hz min, 200 Hz max
- High Time: Pulse width (4,194,304 seconds max)
- On Time: Accumulated time an input is asserted (4,194,304 seconds max)

Connectors

- Expansion Connector: Ribbon cable, 2x5-position, polarized 0.100" pitch
- Relays: Thermoplastic, UL94V-0, 3-wall, 0.375" pitch
- Inputs: PCB terminal block, screw connection, 3.81mm pitch

LED Indicators

- Number of LEDs: 13
 - Power on
 - Relays 1-6
 - Digital Inputs 1-6

Physical

- Size:
 - 8.60in (218.44mm) wide
 - 4.95in (125.73mm) tall
 - 2.16in (54.86mm) deep
- Weight: 17 oz (474 g)
- Enclosure Material: PVC
- Enclosure Flame Rating: UL94 V1

Environmental

- Operating Temperature: -40°F to 150°F (-40°C to 65.5°C)
- Storage Temperature: -40°F to 185°F (-40°C to 85°C)
- Humidity: 5-95%, non-condensing
- Altitude: Up to 2,000m
- Indoor use or NEMA-4 protected location

Electromagnetic Compliance

- IEC CISPR 22, CISPR 24
- FCC 47CFR15 (Class B)
- EN55024 ITE Immunity (2010)
- EN55022 Emissions (2010)

Product Safety Compliance

- UL 61010-1 (Electrical Equipment for Measurement, Control, and Laboratory Use)



PRODUCT OVERVIEW



The X-21s™ Four Relay Expansion Module is used with an X-400/X-600M controller. The X-21s has four relays, each with Form-C contacts (SPDT). A removable terminal connector provides connections to the relays.

Required Controller

One or more X-21s expansion modules can be connected to an X-400/X600M controller with a ribbon cable. The ribbon cable provides both power and communications to the expansion modules.

Controller Features

The X-400 and X-600M are multi-function web-enabled industrial I/O controllers. They perform control, logic, and monitoring functions similar to that of a Programmable Logic Controller (PLC). However, unlike a PLC, this controller is designed for web-based applications from the ground up.

No add-on software or hardware is required. The controllers can be fully configured, programmed and tested using its built-in web server. The web setup pages are intuitive and easy to use and do not require special programming skills.

Applications

The X-400 and X-600M controllers, together with expansion modules, such as the X-21s, provide an easy, flexible, and reliable way to monitor and control systems and devices over a network. The X-21s is suitable for use with moderate loads such as solenoid valves, alarms, and indicator lights.

Features:

- Four SPDT relays (125VAC, 28VDC @ 2.5A) independently controlled
- Removable connector
- Four relay LEDs
- Removable terminal connector
- Powered through expansion bus
- Great for moderate-load applications including:
 - Solenoid valves
 - Alarms
 - Indicator lights
 - and much more...

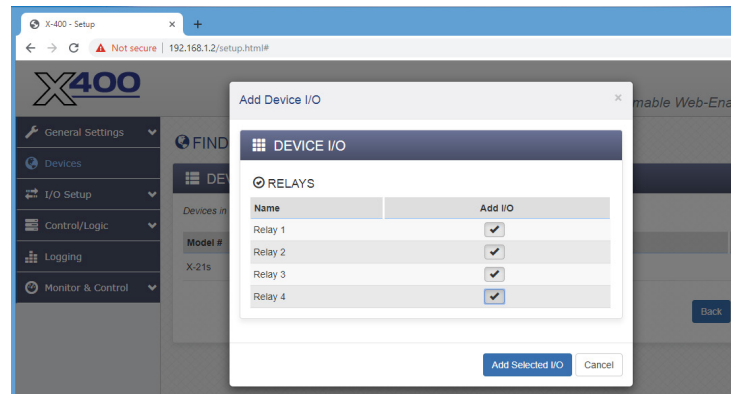

Adding the X-21s on the X-400

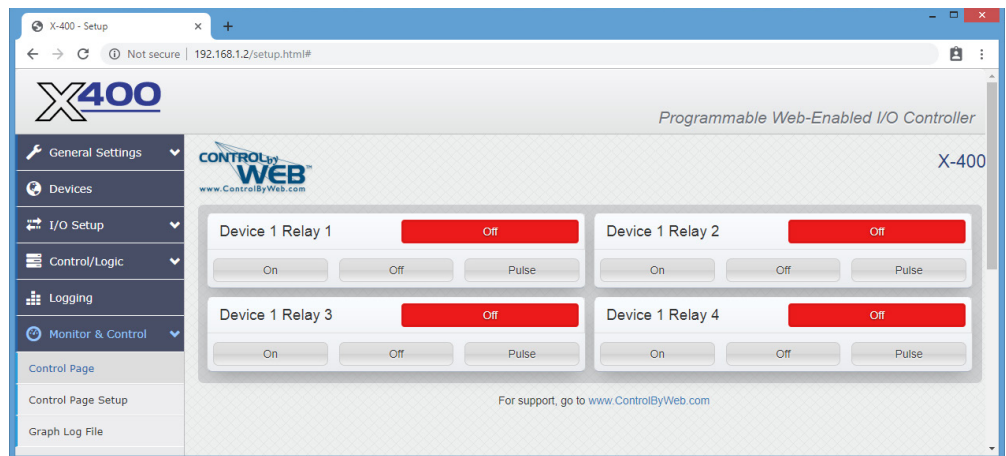

View X-21s components on the X-400's Dashboard

APPLICATIONS & SPECS

TANK BATTERY WITH LEVEL MONITORING SENSORS

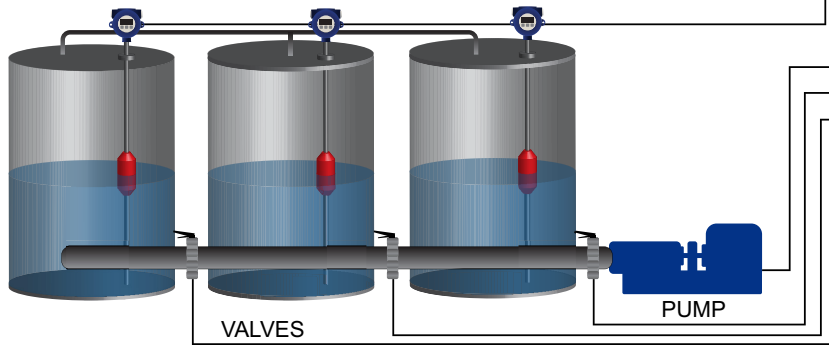

(Images & illustrations are not to scale and do not represent actual wiring)

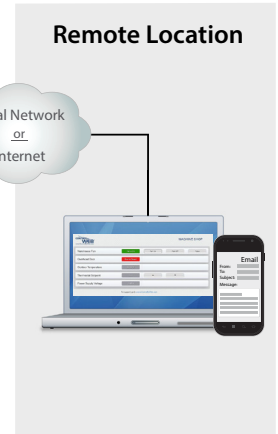

Applications

- ✓ Solenoid Valves
- ✓ Alarms
- ✓ Indicator Lights
- ✓ More...

Models:

- X-21s

Power Requirements

- Voltage: 9-28 VDC (supplied via the X-400 or X-600M controller, 24V recommended)
- Max Current: See table below for typical values at 25°C.

Power Supply	All Relays OFF	All Relays ON
9 VDC	17 mA	270 mA
12 VDC	13 mA	189 mA
24 VDC	7 mA	110 mA

Relay Contacts

- Number of Relays: 4
- Max Voltage: 125VAC, 28VDC
- Max Current: 2.5A (total for each group of 4 relays with shared commons)
- Contact Type: SPDT (Form 1C)
- Load Type: General Purpose
- Contact Resistance: < 100 milliohms initial
- Contact Material: AgNi
- Electrical Life: 100K operations (Min)
- Mechanical Life: 5M cycles (Min)
- Environmental Rating: Over voltage Category II, Pollution Degree 2
- Relay Modes: On/Off or Pulsed
- Pulse Timer Duration: 0.1 to 86,400 Seconds (1-day)

Connectors

- Relays: 12-Position, 3.81mm, Removable
- Expansion Connector: Ribbon cable, 10-conductor, polarized, 2x5-position, 0.100" pitch Provides power and communications for expansion modules (Communications: RS-485)

LED Indicators

- Number of LEDs: 5
 - Power on
 - Relay coil energized 1-4

Physical

- Size:
 - 1.41in (35.7mm) wide
 - 3.88in (98.5mm) tall
 - 3.1in (78mm) deep (not including connector)
- Weight: 4.8 oz (136 g)
- Enclosure Material: Lexan 940 Polycarbonate Plastic
- Enclosure Flame Rating: UL94 V0

Environmental

- Operating Temperature: -40°F to 122°F (-40°C to 50°C)
- Storage Temperature: -40°F to 185°F (-40°C to 85°C)
- Humidity: 5-95%, non-condensing
- Altitude: Up to 2,000m
- Indoor use or NEMA-4 protected location

Electromagnetic Compliance

- IEC CISPR 22, CISPR 24
- FCC 47CFR15 (Class B)
- EN55024 ITE Immunity (2010)
- EN55022 Emissions (2010)

Product Safety Compliance

- IEC 61010-1



PRODUCT OVERVIEW



The X-22s has eight precision analog inputs that can be configured for various voltage ranges and 4-20mA sensors. The X-22s employs a 16-bit SAR A/D converter and can make both single or differential input measurements.

A 5.0V reference output can be used to power potentiometers or other resistance sensing sensors. The X-22s is ideal for measuring precision analog voltages in industrial environments.

One or more X-22s expansion modules can be connected to an X-400 controller with a ribbon cable. The ribbon cable provides both power and communications to the expansion modules.

Features:

- Eight precision analog inputs
- Input Voltage Ranges:
 - $\pm 1.28V$, $\pm 2.56V$, $\pm 5.12V$, $\pm 10.24V$, 4-20mA
- Removable terminal connector
- Powered through expansion bus - no separate power supply connections are required
- High input impedance
- Great for monitoring applications including:
 - Temperature
 - Electrical Current
 - Pressure
 - Fluid Levels
 - and much more...

Other expansion modules with different I/O combinations are also available.



View X-22s inputs on the X-400's Dashboard

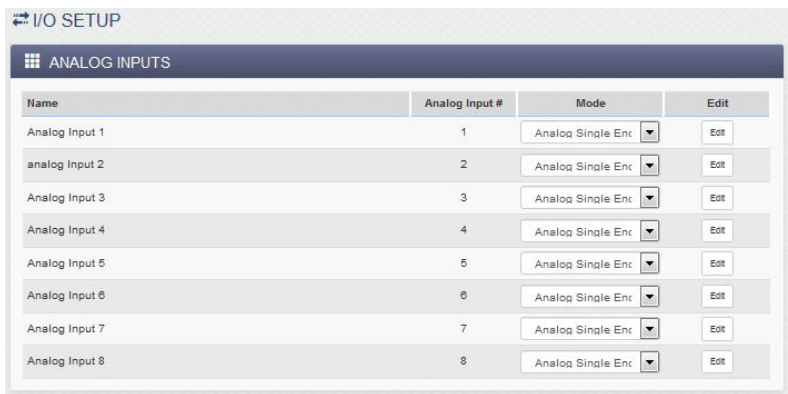

Editing I/O on the X-400

APPLICATIONS & SPECS

Level Monitoring

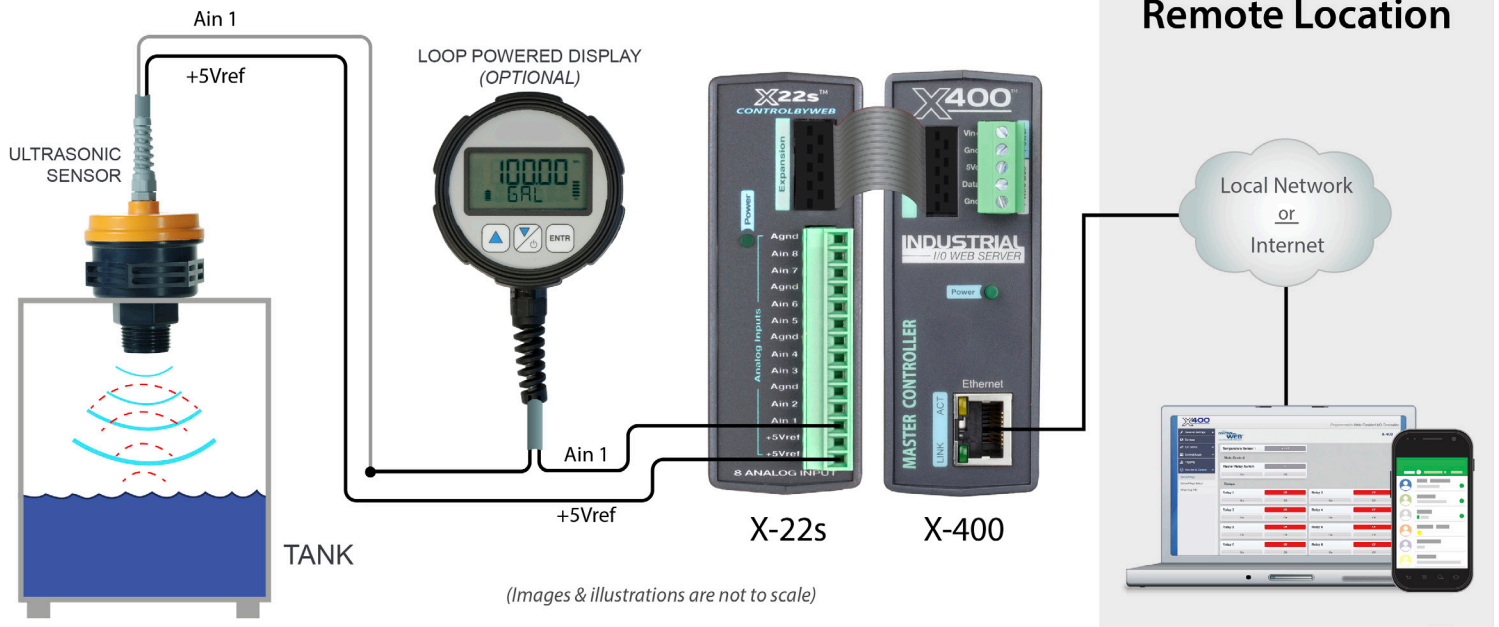

Models:

- X-22s

Power Requirements

- Voltage: 9-28 VDC (supplied via the X-400 controller, 24V recommended)
- Max Current: See table below for typical values at 25°C.

Power Supply	Current (Voltage mode)	Current (Current mode)
9 VDC	20 mA	750 mA
12 VDC	16 mA	555 mA
24 VDC	12 mA	285 mA

Analog Inputs

- Number of Inputs: 8
- Type: Single-ended, differential, 4-20mA (0-20mA), or a combination
- Input Range: $\pm 1.28V$, $\pm 2.56V$, $\pm 5.12V$, $\pm 10.24V$, 4-20mA
- **Note that inputs have high impedance so input range can easily be adjusted using external resistors. Example: 0 to 48 Volts
- Resolution: 16-bit, SAR

Reference Output

- Voltage: 5.00V
- Accuracy: 0.04%
- Temperature Coefficient: 3ppm/°C Max
- Current: 25mA max*
- *Maximum current from the reference may be increased if the environmental temperature is decreased. See users manual for more information.

Connectors

- Inputs: 14-Position, 3.81mm, Removable
- Expansion Connector: Ribbon cable, 10-conductor, polarized, 2x5-position, 0.100" pitch Provides power and communications for expansion modules (Communications: RS-485)

LED Indicators

- Number of LEDs: 1
 - Power on

Physical

- Size:
 - 1.41in (35.7mm) wide
 - 3.88in (98.5mm) tall
 - 3.1in (78mm) deep (not including connector)
- Weight: 5 oz. (142 g)
- Enclosure Material: Lexan 940 Polycarbonate Plastic
- Enclosure Flame Rating: UL94 V0

Environmental

- Operating Temperature*: 0°C to 50°C (32°F to 122°F)
- Storage Temperature: -40°C to 85°C (-40°F to 185°F)
- Humidity: 5-95%, non-condensing
- Indoor use or NEMA-4 protected location
- *Max operating temperature may be increased at the expense of current through the 5V reference. See the X-22s users manual for more details.

Electromagnetic Compliance

- IEC CISPR 22, CISPR 24
- FCC 47CFR15 (Class B)
- EN55024 ITE Immunity (2010)
- EN55022 Emissions (2010)

Product Safety Compliance

- IEC 61010-1





The XW-110 is an easy-to-use wireless temperature sensor with a built-in web server. It measures environmental temperature using an internal sensor (included), or you can attach an external temperature probe (optional) for precise measurement outside of the unit. Users can view current temperature using a web browser, smart phone app, or the XW-110 can send temperature information via email. The XW-110 can be easily and quickly

mounted to a wall or any other workable surface.

Stand-Alone mode makes the XW-110 a self-contained device that requires no additional servers or ControlByWeb devices. In this mode the XW-110 products can provide live, real-time temperatures status directly to users through web browsers or the CBW Mobile app. In addition, stand-alone mode offers the ability to simply monitor temperature status and send out email alerts (which can be converted to text message alerts) either periodically or whenever an alarm condition occurs.

Stand-Alone Mode Configuration Options

-View Real-Time Temperatures - Use the XW-110's built in web pages to view real-time temperatures: Connects directly to Wi-Fi network, no gateway devices required - AC adapter for main power and batteries for backup - No cloud server required.

-Email alerts during alarm conditions - Send emails for high/low temp alarms: Connects directly to Wi-Fi network, no gateway devices required - Battery/AC adapter powered DHCP or static IP address (no static IP required) - No cloud server required - No port forwarding required - Supports encrypted & un-encrypted email servers.

-Control relays in remote locations - Control the relays on other ControlByWeb devices to turn on lights, bells, alerts, etc.: Connects directly to Wi-Fi network - no gateway devices required - Battery or AC adapter powered - Control remote relays on other ControlByWeb products.

Slave mode Configuration Options:

Slave mode is used for measuring and reporting the temperature to other ControlByWeb devices. In this mode the XW-110's web interface is not directly accessible to the user, instead temperature status is simply transmitted to another ControlByWeb device that supports temperature monitoring, such as the X-600M controller, which acts as a "master" device. The master device uses the XW-110's temperature information as it would use information collected by any other sensor.

Note on power: The XW-110 is powered by an external 5VDC wall transformer, or by two internal AA batteries. Only use batteries to provide backup power, or for modes where the web server is not being used. Some configurations consume more power than others which can make battery

PRODUCT OVERVIEW

operation impractical. Having more features enabled and/or increased sampling frequencies lead to lower battery life.

There is no special software to download, no drivers to install, and no monthly subscription. Using the XW-110 is just as easy to monitor whether you are in the field, in the office, or on vacation. It is the ultimate solution to your wireless temperature monitoring needs!

Features:

- Monitor one temperature sensor
- Wireless Wi-Fi 802.11 b/g/n
- Transmission range up to 250ft*
- No sensor calibration needed
- Small data packets provide long battery life
- Built-in web server for configuration and remote monitoring
- Temperature sensor is accurate to +/-0.5°C from -10°C to +85°C
- Powered by external DC power adapter or two AA batteries (battery usage for backup/low power applications only)
- Longer length air/submersible temperature probes available - Sensors are interchangeable and need no calibration
- Temperature status can control relay on another ControlByWeb device
- Protocols supported: HTTP, XML, SMTP
- Simple and easy to use

*Transmission distance can vary depending upon environmental conditions, interference from other Wi-Fi devices, obstacles, etc.

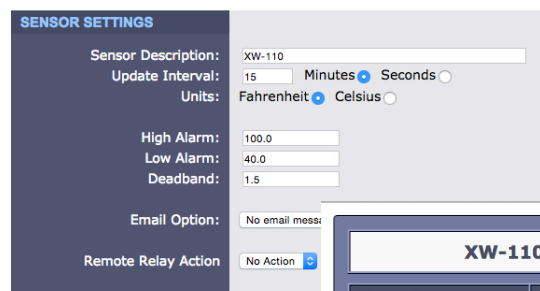
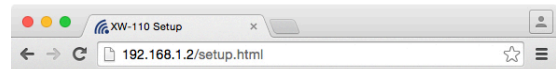

Submit Reset Changes

Sensor Page

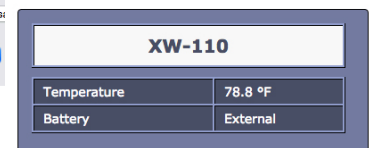

Control Page

APPLICATIONS & SPECS

Monitoring temperature on a computer/smartphone



Models:

- XW-110B

Power Requirements

- Voltage: 2AA batteries, or external 5VDC power supply
- Max Current: 500ma max (via DC power wall adapter)
- DC Jack: 5.5mm barrel x 2.5mm center pin (positive)

Battery

- Internal: Two replaceable 1.5V "AA" cells
- Power Consumption: 27-770uA sleep, 59mA active RX, 229mA TX (at +12dBm)
- Battery Life: Up to 1-year, depending on mode, security and reporting frequency. Battery life is affected by mode, reporting interval, security, DHCP, DNS, battery temperature, and other variables.
- Battery Usage: Battery voltage is measured and periodically reported

Wireless

- Network Standards: IEEE 802.11 b/g/n
- Frequency Band: 2.412 - 2.462 GHz
- Wi-Fi Security Standards: Open, WEP, WPA, WPA2
- Network Settings: DHCP or Static
- Wireless Range: Up to 250ft (typical for Wi-Fi devices) depends on environment
- Antenna: Integral chip antenna, 1.9 dBi.
- RF Output Power (typ): 14dBm (802.11b/g), 12dBm (802.11n)

Operation

- Provisioning: Via internal web server (no cables or PC utilities needed)
- Access Point: Yes, push button activated (setup via web page)
- WPS: Yes, push button activated (Wi-Fi Protected Setup)
- Connectivity: Intermittently connected or always connected
- XCD Data Packet: UDP, 10-bytes (See Appendix A)
- Remote Server: ControlByWeb's X-600M™, X-300™ or cloud-based server
- Polling: state.xml (only with always-connected)

Internal Push Buttons

- Button 1: Force access-point mode
- Button 2: Activate WPS mode

Temperature Sensors

- Maximum Number of Sensors: 1
- Type: Digital "1-wire" thermometer probe
- Temperature Range: -67°F to 257°F (-55°C to +125°C)
- Accuracy: ±0.5°C (from -10°C to +85°C)
- Sensor Functions: Monitor Temperature, Email Alerts, Control Remote Relay

Protocols

- HTTP, XML, SMTP, Remote Services

Physical

- Location: Indoor use or NEMA-4 protected location
- Using Alkaline Batteries: -18°C to 55°C (0°F to 130°F)
- Operating Temperature: -40°C to 65°C (-40°F to 150°F)
- Storage Temperature: -40°C to 85°C (-40°F to 185°F)
- Humidity: 5-95%, non-condensing
- Size:
 - 3.16 (80mm) wide
 - 3.04in (77mm) tall
 - 0.91in (23mm) deep
- Weight: 2.4 oz (68g), no batteries
- Enclosure Material: Lexan 940 Polycarbonate Plastic
- Enclosure Flame Rating: UL94 V0

Password Settings

- Password protection on setup page: Yes
- Password protection on control page: Optional
- Password Encoding: Base 64
- Max Password Length: 13 Characters

Electromagnetic Compliance

- FCC ID: 2AE4Z-XWD001
- IC: 21441-XWD001
- FCC 47CFR15 (Class B)
- IEC CISPR 22, CISPR 24
- EN55024 ITE Immunity (2010)
- EN55022 Emissions (2010)

Product Safety Compliance

- IEC 61010-1





The XW-110 is an easy-to-use wireless temperature sensor with a built-in web server. It measures environmental temperatures using up to 3 external temperature probes (one included) for precise measurement outside of the unit. Users can view current temperature using a web browser, smart phone app, or the XW-110 can send temperature information via email. The XW-

110 can be easily and quickly mounted to a wall or any other workable surface.

The XW-110 Plus model, allows you to periodically log temperature data. The temperature data is stored internally (max 28,829 logs), and can be sent daily via email. The XW-110 Plus is an ideal solution for maintaining compliance with FDA requirements to maintain food temperatures in coolers and freezers. No more manually logging temperature data by hand!

Stand-Alone mode makes the XW-110 a self-contained device that requires no additional servers or ControlByWeb devices. In this mode the XW-110 products can provide live, real-time temperatures status directly to users through web browsers or the CBW Mobile app. In addition, stand-alone mode offers the ability to simply monitor temperature status and send out email alerts (which can be converted to text message alerts) either periodically or whenever an alarm condition occurs.

Stand-Alone Mode Configuration Options

-View Real-Time Temperatures - Use the XW-110's built in web pages to view real-time temperatures: Connects directly to Wi-Fi network, no gateway devices required - AC adapter for main power and batteries for backup - No cloud server required.

-Email alerts during alarm conditions - Send emails for high/low temp alarms or power failures: Connects directly to Wi-Fi network, no gateway devices required - Battery/AC adapter powered DHCP or static IP address (no static IP required) - No cloud server required - No port forwarding required - Supports encrypted & un-encrypted email servers.

-Control relays in remote locations - Control the relays on other ControlByWeb devices to turn on lights, bells, alerts, etc.: Connects directly to Wi-Fi network - no gateway devices required - Battery or AC adapter powered - Control remote relays on other ControlByWeb products.

Note on power: The XW-110 is powered by an external 5VDC wall transformer, or by two internal AA batteries. Only use batteries to provide backup power, or for modes where the web server is not being used. Some configurations consume more power than others which can make battery operation unpractical. Having more features enabled and/or increased sampling frequencies lead to lower battery life.

There is no special software to download, no drivers to install, and no monthly

PRODUCT OVERVIEW

subscription. Using the XW-110 is just as easy to monitor whether you are in the field, in the office, or on vacation. It is the ultimate solution to your wireless temperature monitoring needs!

Features:

- Monitor up to 3 temperature sensors
- Wireless Wi-Fi 802.11 b/g/n
- Transmission range up to 250ft*
- Log temperature data (data sent via daily email)
- Send power failure email alerts
- No sensor calibration needed
- Small data packets provide long battery life
- Built-in web server for configuration and remote monitoring
- Temperature sensor is accurate to +/-0.5°C from -10°C to +85°C
- Powered by external DC power adapter or two AA batteries (battery usage for backup/low power applications only)
- Longer length air/submersible temperature probes available - Sensors are interchangeable and need no calibration
- Temperature status can control relay on another ControlByWeb device
- Protocols supported: HTTP, XML, SMTP, Modbus, Remote Services, Data Logging
- Simple and easy to use

*Transmission distance can vary depending upon environmental conditions, interference from other Wi-Fi devices, obstacles, etc.

XW-110 Plus™ Wireless Temperature Sensor

Main | WiFi Networks | Email | Password | Date/Time | Sensor | Control Page

MODULE SETTINGS

Module Description: XW-110P

Temperature Update Interval: 5 Minutes Seconds

Units: Fahrenheit Celsius

Logging: Off On

SENSOR 1

Sensor Description: Sensor 1

Sensor Address: 0000000000000000

Offset: 0.0

Alarm 1: 100.0 High Low

Alarm 2: 40.0 High

Deadband: 1.0

Include Temperature: On Control Page

Email Option: No email messages

Remote Services: No action

Remote Relay Action: No Action when Al

SENSOR 2

XW-110P	
Sensor 1	x.x °F
Sensor 2	x.x °F
Sensor 3	x.x °F
Battery	External
Current Time: Fri, 01 Jan 2016 08:11:23	

Sensor Page

Control Page

APPLICATIONS & SPECS

Monitoring temperature on a computer/smart phone



Models:

- XW-110P

Power Requirements

- Voltage: 2AA batteries, or external 5VDC power supply
- Max Current: 500ma max (via DC power wall adapter)
- DC Jack: 5.5mm barrel x 2.5mm center pin (positive)

Battery

- Internal: Two replaceable 1.5V "AA" cells
- Power Consumption: 27-770uA sleep, 59mA active RX, 229mA TX (at +12dBm)
- Battery Life: Up to 1-year, depending on mode, security and reporting frequency. Battery life is affected by mode, reporting interval, security, DHCP, DNS, battery temperature, and other variables.
- Battery Usage: Battery voltage is measured and periodically reported

Wireless

- Network Standards: IEEE 802.11 b/g/n
- Frequency Band: 2.412 - 2.462 GHz
- Wi-Fi Security Standards: Open, WEP, WPA, WPA2
- Network Settings: DHCP or Static
- Wireless Range: Up to 250ft (typical for Wi-Fi devices) depends on environment
- Antenna: Integral chip antenna, 1.9 dBi.
- RF Output Power (typ): 14dBm (802.11b/g), 12dBm (802.11n)

Operation

- Provisioning: Via internal web server (no cables or PC utilities needed)
- Access Point: Yes, push button activated (setup via web page)
- WPS: Yes, push button activated (Wi-Fi Protected Setup)
- Connectivity: Intermittently connected or always connected
- XCD Data Packet: UDP, 10-bytes (See Appendix A)
- Remote Server: ControlByWeb's X-600M™, X-300™ or cloud-based server
- Polling: state.xml (only with always-connected)

Internal Push Buttons

- Button 1: Force access-point mode
- Button 2: Activate WPS mode

Temperature Sensors:

- Number of Sensors: 1-3
- Type: Digital "1-wire" thermometer probe
- Temperature Range: -67°F to 257°F (-55°C to +125°C)
- Accuracy: ±0.5°C (from -10°C to +85°C)
- Sensor Functions: Monitor Temperature, Email Alerts, Control Remote Relay

Real-Time Clock

- Manual or NTP(Network Time Protocol) setup
- NTP Sync Period: Once, Daily, Weekly, On Power-up
- Auto Daylight Savings Adjustment

Protocols

- HTTP, XML, SMTP, Modbus (XW-110 Plus), Remote Services, Data Logging (XW-110 Plus)

Logging

- Log File Size: 1,800 Entries
- Buffer Architecture: Circular Buffer
- (Log data can be emailed every 24 hours)

Physical

- Location: Indoor use or NEMA-4 protected location
- Using Alkaline Batteries: -18°C to 55°C (0°F to 130°F)
- Operating Temperature: -40°C to 65°C (-40°F to 150°F)
- Storage Temperature: -40°C to 85°C (-40°F to 185°F)
- Humidity: 5-95%, non-condensing

- Size:
 - 3.16 (80mm) wide
 - 3.04in (77mm) tall
 - 0.91in (23mm) deep
- Weight: 2.4 oz (68g), no batteries
- Enclosure Material: Lexan 940 Polycarbonate Plastic
- Enclosure Flame Rating: UL94 V0

Password Settings

- Password protection on setup page: Yes
- Password protection on control page: Optional
- Password Encoding: Base 64
- Max Password Length: 13 Characters

Electromagnetic Compliance

- FCC ID: 2AE4Z-XWD001
- IC: 21441-XWD001
- FCC 47CFR15 (Class B)
- IEC CISPR 22, CISPR 24
- EN55024 ITE Immunity (2010)
- EN55022 Emissions (2010)

Product Safety Compliance

- IEC 61010-1



PRODUCT OVERVIEW



The XW-111 is an easy-to-use, wireless digital input monitoring device with a built-in web server. The XW-111 monitors and reports the status of switch closure sensors and alarms. It's ideal for applications where a device's status must be monitored and Ethernet wiring is not accessible or practical to install.

The XW-111 can sense the state of up to two switch-closure sensors, such as: push buttons,

magnetic door alarm switches, micro-switches, or any device which has a relay or switch closure output. The XW-111 can be configured for the alarm to be active when the switch is either open or closed.

Stand-Alone mode makes the XW-111 a self-contained device that requires no additional servers or ControlByWeb devices. While in Stand-Alone mode the XW-111 products can provide live, real-time input status directly to users through web browsers or the CBW Mobile app. In addition, Stand-Alone mode offers the ability to simply monitor input status and send out email alerts (which can be converted to text message alerts) either periodically or whenever an alarm condition occurs.

Stand-Alone Mode:

-View real-time input status -Use the XW-111's built in web pages to view real-time input status: Connects directly to Wi-Fi network, no gateway devices required - AC adapter for main power and batteries for backup - No cloud server required

-Email alerts during alarm conditions - Send emails for on/off sensor status: Connects directly to Wi-Fi network, no gateway devices required - Battery/AC adapter powered DHCP or static IP address (no static IP required) - No cloud server required - No port forwarding required - Supports encrypted & un-encrypted email servers

-Control relays in remote locations - Control the relays on other ControlByWeb devices to turn on lights, bells, alerts, etc.: Connects directly to Wi-Fi network - no gateway devices required - Battery or AC adapter powered - Control remote relays on other ControlByWeb products

Slave Mode:

Slave mode is used for measuring and reporting an input status to other ControlByWeb devices. While in Slave mode the XW-111's web interface is not directly accessible to the user, instead input status is simply transmitted to another ControlByWeb device that supports input status monitoring, such as the X-600M controller, which acts as a "master" device. The master device uses the XW-111's input status information as it would use information collected by any other input.

Note on power: The XW-111 is powered by an external 5VDC wall transformer, or by two internal AA batteries. Only use batteries to provide backup power, or for modes where the web server is not being used. Some configurations consume more power than others which can make battery operation unpractical. Having more features

enabled and/or increased sampling frequencies lead to lower battery life.

There is no special software to download, no drivers to install, and no monthly subscription. Monitoring inputs with the XW-111 is easy whether you are in the field, in the office, or on vacation. It is the ultimate solution to your wireless digital input monitoring needs!

Features:

Wireless Wi-Fi 802.11 b/g/n

Transmission range up to 250ft*

Small data packets provide long battery life

Built-in web server for configuration and remote monitoring

Connect a variety of switch-closure sensors

Powered by external DC power adapter or two AA batteries (battery usage for backup/low power applications only)

Each input status can control a relay on another ControlByWeb device

Simple and easy to use

* Transmission distance can vary depending upon environmental conditions, interference from other Wi-Fi devices, obstacles, etc.

XW111™ Wireless Digital Input Monitor

Main WiFi Networks Email Password Date/Time Inputs Control Page

MODULE SETTINGS

Module Description: XW-111
Control Page Refresh Rate: 3 Seconds

INPUT 1

Description: Input 1
On Status Text: On
On Status Color: Green Red Yellow Blue Grey
Off Status Text: Off
Off Status Color: Green Red Yellow Blue Grey
Email Alert: No email messages
Email Schedule: Edit
Email Deadband: 0.0 Minimum seconds between emails
Remote Relay: No remote relay control
Remote Service: Send State Msg on Input Change

INPUT 2

Description: Input 2
On Status Text: On
On Status Color: Green Red Yellow Blue Grey
Off Status Text: Off
Off Status Color: Green Red Yellow Blue Grey
Email Alert: No email messages
Email Schedule: Edit
Email Deadband: 0.0 Minimum seconds between emails
Remote Relay: No remote relay control
Remote Service: Send State

Submit Reset Changes

Inputs Page

XW-111	
Input 1	Off
Input 2	Off
Battery	100 %
Current Time: Fri, 01 Jan 2016 08:11:27	

Control Page

APPLICATIONS & SPECS

Monitoring the XW-111 digital inputs' status on a computer/ smartphone

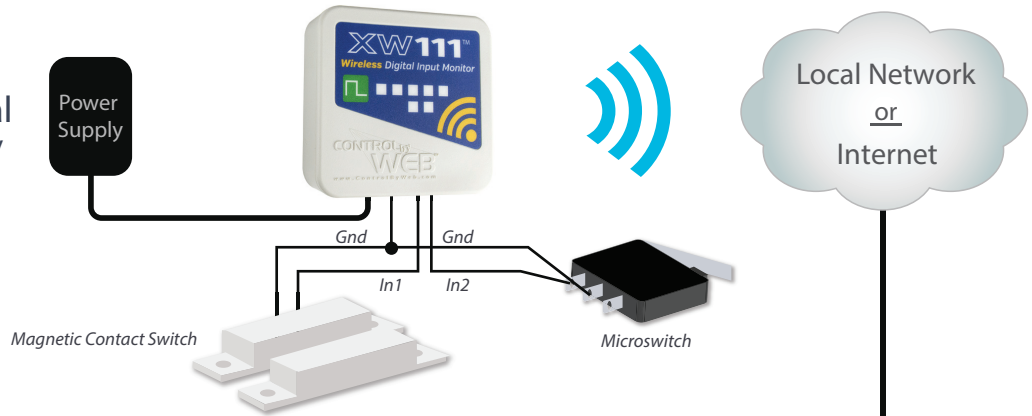

Models:

- XW-111B

Power Requirements

- Voltage: 2AA batteries, or external 5VDC power supply
- Max Current: 500ma max (via DC power wall adapter)
- DC Jack: 5.5mm barrel x 2.5mm center pin (positive)

Battery

- Internal: Two replaceable 1.5V "AA" cells
- Power Consumption: 27-770uA sleep, 59mA active RX, 229mA TX (at +12dBm)
- Battery Life: Up to 1-year, depending on mode, security and reporting frequency. Battery life is affected by mode, reporting interval, security, DHCP, DNS, battery temperature, and other variables.
- Battery Usage: Battery voltage is measured and periodically reported

Wireless

- Network Standards: IEEE 802.11 b/g/n
- Frequency Band: 2.412 - 2.462 GHz
- Wi-Fi Security Standards: Open, WEP, WPA, WPA2
- Network Settings: DHCP or Static
- Wireless Range: Up to 250ft (typical for Wi-Fi devices) depends on environment
- Antenna: Integral chip antenna, 1.9 dBi.
- RF Output Power (typ): 14dBm (802.11b/g), 12dBm (802.11n)

Operation

- Provisioning: Via internal web server (no cables or PC utilities needed)
- Access Point: Yes, push button activated (setup via web page)
- WPS: Yes, push button activated (Wi-Fi Protected Setup)
- Connectivity: Intermittently connected or always connected
- XCD Data Packet: UDP, 10-bytes (See Appendix A)
- Remote Server: ControlByWeb's X-600M™, X-300™ or cloud-based server
- Polling: state.xml (only with always-connected)



Internal Push Buttons

- Button 1: Force access-point mode
- Button 2: Activate WPS mode

Digital Inputs

- Number of Inputs: 2
- Type: Non-Isolated
- Voltage Range: 0-3.3VDC
- Current: 200K Pullup
- Minimum Hold Time: (Awake) 30mS
- Minimum Hold Time: (Asleep) 100ms
- Input Isolation: Non-Isolated
- Input Functions: Monitor State, Trigger Email Alerts, Control Remote Relays
- Edge Trigger: Rising, Falling or Both

Physical

- Location: Indoor use or NEMA-4 protected location
- Using Alkaline Batteries: -18°C to 55°C (0°F to 130°F)
- Operating Temperature: -40°C to 65°C (-40°F to 150°F)
- Storage Temperature: -40°C to 85°C (-40°F to 185°F)
- Humidity: 5-95%, non-condensing
- Size:
 - 3.16 (80mm) wide
 - 3.04in (77mm) tall
 - 0.91in (23mm) deep
- Weight: 2.4 oz (68g), no batteries

- Enclosure Material: Lexan 940 Polycarbonate Plastic
- Enclosure Flame Rating: UL94 V0

Password Settings

- Password protection on setup page: Yes
- Password protection on control page: Optional
- Password Encoding: Base 64
- Max Password Length: 13 Characters

Electromagnetic Compliance

- FCC ID: 2AE4Z-XWD001
- IC: 21441-XWD001
- FCC 47CFR15 (Class B)
- IEC CISPR 22, CISPR 24
- EN55024 ITE Immunity (2010)
- EN55022 Emissions (2010)

Product Safety Compliance

- IEC 61010-1



PRODUCT OVERVIEW



Water leaks can occur when you least expect them! Leaks that are left undetected can lead to thousands of dollars worth of repairs and equipment replacement costs. Monitor water leaks in server rooms, around water heaters, bathrooms, and areas near water tanks or pipes. Don't let a leaky pipe set you back!

The XW-112 is an easy-to-use and effective water leak detection system. This wireless device monitors the presence of conductive non-flammable liquids using a GRI-2605 liquid detection sensor (included). It's ideal for applications where liquid levels or water leaks must be monitored and Ethernet wiring is not accessible or practical to install.

Built-in Web Server

The XW-112 is a self-contained device that does not require any additional equipment such as hubs, gateways, or servers. The XW-112 provides real-time water status to users through a standard web browser or the CBW Mobile app*. In addition, it offers the ability to monitor the water sensor's status and send out email alerts (which can be converted to text message alerts) whenever water is detected.

*Note that accessing XW-112 remotely over the Internet requires your local router to be setup to forward incoming requests to the XW-112.

Email/Text Notifications

Receive email/text notifications in the event of a pipe burst, slow leak, or rising water levels in a tank for from ground water.

When the XW-112 Wi-Fi Water Detector detects the presence of water, it sends email notifications to up to 3 email addresses to ensure that the proper personnel is notified. Convert email messages to text messages using your wireless carrier's email to SMS gateway. (Carriers offer this as a free service.)

Alarm Control

In addition to email/text notifications, the XW-112 can send messages to control other ControlByWeb devices when it detects the presence of water. For example, a WebRelay that is wired to an alarm notification device, such as a bell or flashing light, can be turned on by the XW-112 when water is detected. These ControlByWeb devices can be located in the same building, across campus, or they can be located in a location that's across the world!

Power Failure Notification

Power failures can be the cause of disasters or they may disable detection systems so that alerts are not sent out when disasters occur. For example, a power failure

can disable sump pumps which can quickly cause flooding. Early notification of power failures can be extremely valuable in many applications.

The XW-112 can be configured to send out email/text notifications in the event of a power loss. This feature requires good batteries to be installed in the XW-112, and backup power must be provided to the local network that provides internet connectivity, such as a wireless access point. (Note that during times of power failure, the unit will not detect the presence of water.)

Features:

- Wireless Wi-Fi 802.11 b/g/n
- Built-in web server provides stand-alone operation (i.e. direct access to unit without using a cloud server - No monthly or annual service fees)
- GRI-2605 liquid detection sensor is included
- Powered from a 5-Volt DC power adapter
- Two "AA" batteries provide backup power to send a power-fail alarm
- Alarm can control relays on other ControlByWeb devices
- Send encrypted email alarms and weekly status alerts (up to 3 addresses)
- Simple and easy to use
- Includes auxiliary protocols: XML and Remote Services
- Static or DHCP IP address configuration
- 5-year warranty

XW112™ Wi-Fi Water Detector

Main WiFi Networks Email Password Water Sensor Control Page

SENSOR SETTINGS	
Description:	Wi-Fi Water Detector
Control Page Refresh Rate:	3 Seconds
Email Alerts:	On <input checked="" type="radio"/> Off <input type="radio"/>
Remote Relay:	No remote relay control
Remote Service:	Send State Msg on sensor Change <input type="checkbox"/>

Submit Reset Changes

Sensor Page

192.168.1.2/index.html

Wi-Fi Water Detector	
Water Sensor	Water Detected!
Battery	External

Control Page

APPLICATIONS & SPECS

Wireless Water Leak Monitoring

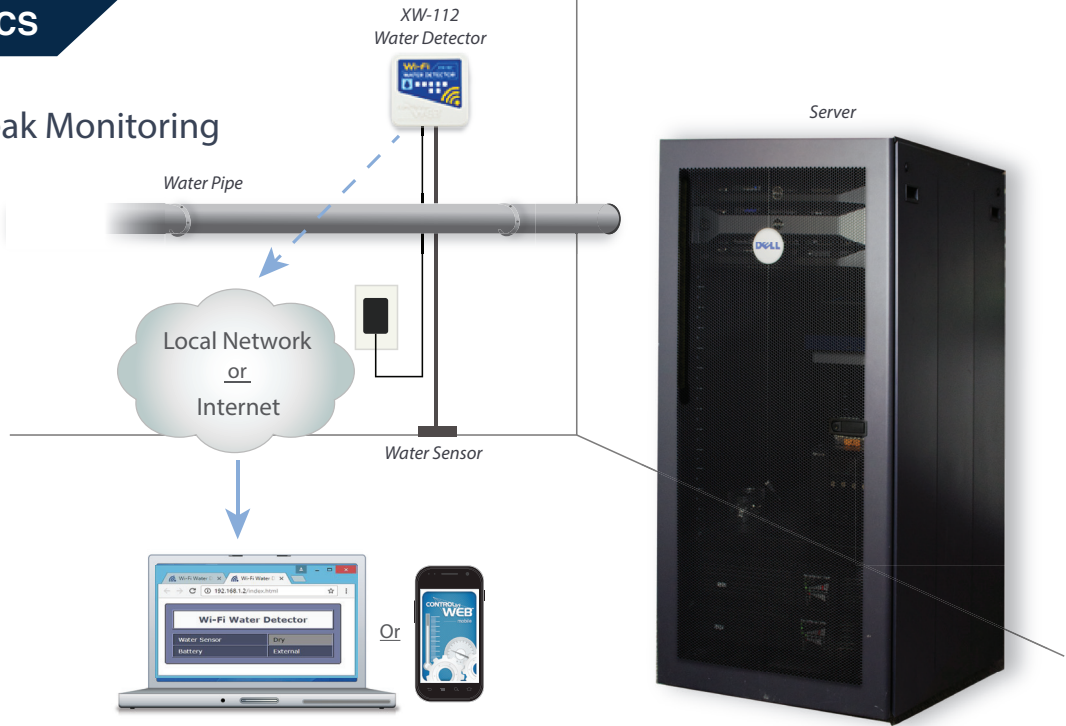

Power Requirements

- Voltage: 5VDC power supply
- Max Current: 500ma max (via DC power wall adapter)
- DC Jack: 5.5mm barrel x 2.5mm center pin (positive)

Battery

- Internal: Two replaceable 1.5V "AA" cells
- Power Consumption: 59mA active RX, 229mA TX (at +12dBm)
- Battery Usage: Battery voltage is measured and periodically reported
- Battery Life: On external power failure, 3 days minimum

Wireless

- Network Standards: IEEE 802.11 b/g/n
- Frequency Band: 2.412 - 2.462 GHz
- Wi-Fi Security Standards: Open, WEP, WPA, WPA2
- Network Settings: DHCP or Static
- Wireless Range: Up to 250ft (typical for Wi-Fi devices) depends on environment
- Antenna: Integral chip antenna, 1.9 dBi.
- RF Output Power (typ): 14dBm (802.11b/g), 12dBm (802.11n)

Operation

- Provisioning: Via internal web server (no cables or PC utilities needed)
- Access Point: Yes, push button activated (setup via web page)
- WPS: Yes, push button activated (Wi-Fi Protected Setup)
- Connectivity: Intermittently connected or always connected
- XCD Data Packet: UDP, 10-bytes (See Appendix A)
- Remote Server: ControlByWeb's X-600M™, X-300™ or cloud-based server
- Polling: state.xml (only with always-connected)

Internal Push Buttons

- Button 1: Force access-point mode
- Button 2: Activate WPS mode

Digital Inputs

- Number of Inputs: 1
- Type: Non-Isolated
- Current: 12.4K Pullup
- Minimum Hold Time: 20ms
- Input Functions: Monitor Liquid State, Trigger Email/Text Alerts, Control Remote Relays
- Edge Trigger: Rising, Falling or Both

Water Sensor

- Model: GRI 2605
- Operating Voltage: 5 VDC
- Operating Current: 10 mA
- Wire Connections:
 - Red: +5V
 - Green: In
 - Black: Ground
 - White: Ground
- Lead Wire: 6ft (1.83m)

Physical

- Location: Indoor use or NEMA-4 protected location
- Using Alkaline Batteries: -18°C to 55°C (0°F to 130°F)
- Operating Temperature: -40°C to 65°C (-40°F to 150°F)
- Storage Temperature: -40°C to 85°C (-40°F to 185°F)
- Humidity: 5-95%, non-condensing



- Size:
 - 3.16 (80mm) wide
 - 3.04in (77mm) tall
 - 0.91in (23mm) deep
- Weight: 2.4 oz (68g), no batteries
- Enclosure Material: Lexan 940 Polycarbonate Plastic
- Enclosure Flame Rating: UL94 V0

Password Settings

- Password protection on setup page: Yes
- Password protection on control page: Optional
- Password Encoding: Base 64
- Max Password Length: 13 Characters

Electromagnetic Compliance

- FCC ID: 2AE4Z-XWD001
- IC: 21441-XWD001
- FCC 47CFR15 (Class B)
- IEC CISPR 22, CISPR 24
- EN55024 ITE Immunity (2010)
- EN55022 Emissions (2010)

Product Safety Compliance

- IEC 61010-1



PRODUCT OVERVIEW

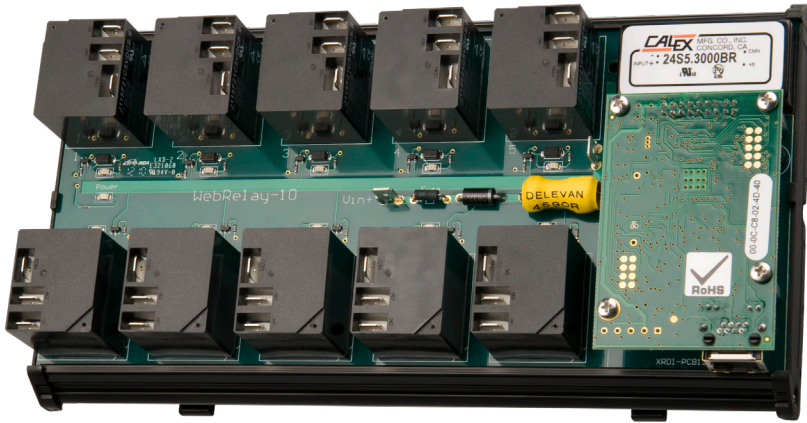

WebRelay-10™ is a robust, industrial relay board with Ethernet communications. It provides remote relay control through its ten large 30-Amp relays.

The relays can be individually controlled using a standard web browser or by sending commands from a custom control application.

It is self-contained with a built-in web server, and requires no external software, additional network modules, or computers.

WebRelay-10™ is designed for industrial applications and can be DIN-Rail mounted inside a control cabinet. Tab connectors (1/4 inch) are used for power and relay contact connection.

Features:

- Ten independent 30-Amp Relays (Form C, SPDT).
- Built-in web server for browser-based setup and control.
- No special software or device drivers required.
- XML status and control page make communications with custom computer applications simple.
- Can operate as a Modbus TCP/IP slave.
- On/Off and Pulse modes.
- Wide power supply range (10-36 VDC).
- DIN-Rail mountable.
- LEDs indicate the current relay state.
- 1/4" tab-connectors.
- UL/CUL listed relays (E197852).

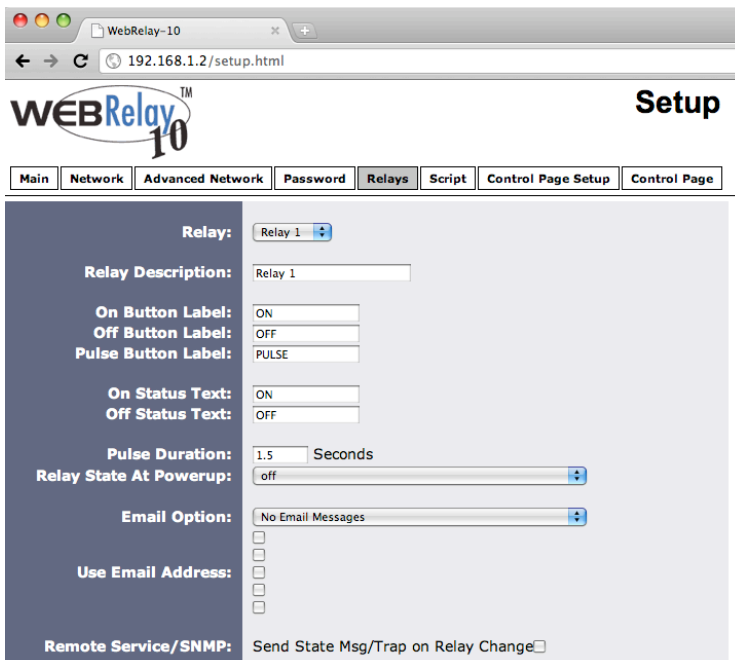

Relay Setup Page



WebRelay-10 Control Page

APPLICATIONS & SPECS

Lighting Control

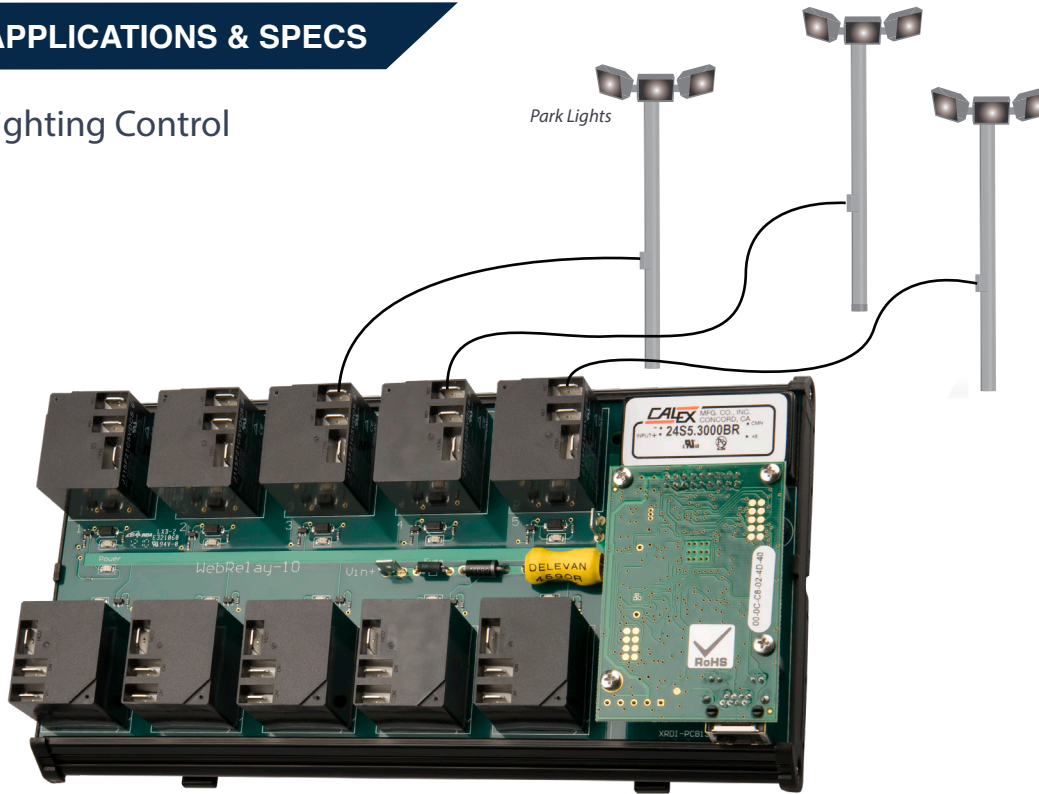

Additional Applications

- ✓ Automation Controller
- ✓ Industrial Automation
- ✓ Car Wash Industry
- ✓ More...

Models:

- X-WR-10R12-I

Power Requirements

- Voltage: 10-36VDC
- Max Current: 53mA - 1.2A
- Note: Current based upon voltage applied and device settings. See users manual for complete breakdown.

Relay Contacts

- Number of Relays: 10
 - N.O.
 - 40A @ 240VAC resistive
 - 30A @ 277VAC General Purpose
 - 2hp @ 250VAC
 - N.C.
 - 30A @ 240VAC, 30VDC resistive
 - 20A @ 277VAC General Purpose
 - 1-1/2 hp @ 250VAC
- Contact Type: SPDT (Form 1C)
- Load Type: General Purpose
- Contact Resistance: < 30 milliohms initial
- Contact Material: AgSnO2
- Electrical Life: 100K cycles (Typical)
- Mechanical Life: 10M cycles (Typical)
- Environmental Rating: Over voltage Category II, Pollution Degree 2
- Relay Modes: ON/OFF or Pulse
- Pulse Timer Duration: 0.1 to 86,400 Seconds (1-day)
- Relay Connections: 1/4" Tab Terminals

Real-Time Clock

- Manual or NTP(Network Time Protocol) setup
- NTP Sync Period: Once, Daily, Weekly, On Power-up
- Auto Daylight Savings Adjustment
- Battery (capacitor) Power Backup

Capacitor Power Backup

- Backup Functions: Retain Real-Time Clock, External Variables, Relay State
- Backup Duration: 3 days minimum

Network

- Type: 10/100 Base-T Ethernet Port
- Setup: Static IP address assignment, HTTP port selectable

LED Indicators

- Number of LEDs: 13
 - Power on
 - Relay coil energized 1-10
 - Network linked
 - Network activity

Physical

- Size:
 - 9.125in (232mm) wide
 - 4.25in (126mm) tall
 - 2.425in (62mm) deep
- Weight: 22 oz (626 grams)
- Enclosure Material: PVC
- Enclosure Flame Rating: UL94 V1
- Operating Temperature: -40°F to 150°F (-40°C to 65.5°C)

Protocols

- HTTP, XML, Modbus, SNMP, SMTP, Remote Services, and Remote Monitoring

Logging

- Log File Size: 512K max 17900 logs
- Storage: Nonvolatile Flash
- Buffer Architecture: Circular Buffer
- Log data can be periodically read and stored on a computer

Password Settings

- Password protection on setup page: Yes
- Password protection on control page: Optional
- Password Encoding: Base 64
- Max Password Length: 10 Characters

Electromagnetic Compliance

- IEC CISPR 22, CISPR 24
- FCC 47CFR15 (Class B)
- EN55024 ITE Immunity (2010)
- EN55022 Emissions (2010)

Product Safety Compliance

- IEC 61010-1



PRODUCT OVERVIEW

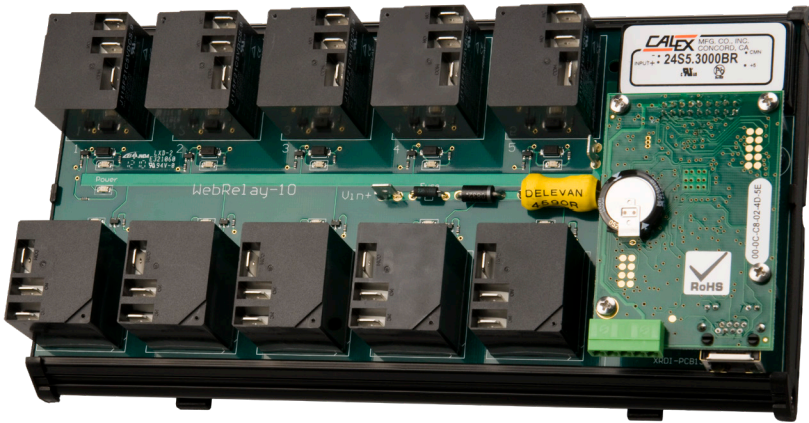

The full featured WebRelay-10 Plus™ has all the features found on WebRelay-10™, plus much more.

Additional features include an event scheduler, customizable email alerts, two discrete inputs, device logging, and remote temperature and/or humidity monitoring.

Features:

- Event scheduler with yearly calendar. Schedule up to 100 events.
- Customizable email alerts.
- Up to eight temperature and/or humidity sensors can be added for environmental monitoring (one temperature sensor included).
- Dry-contact sensors or switches can be connected for local control of relays or for monitoring external devices.
- Logging; log relay changes, events, Modbus TCP/IP requests, high/low temperatures, input changes, network traffic, and more.
- Real-time clock, can automatically adjust for daylight savings time, sync with NTP server.
- System log provides detailed diagnostic information.
- Simple scripts can be written in BASIC for advanced functionality.
- Configure manually or with DHCP.

WebRelay-10		
Input 1	ON	Reset Count Count = 157
Input 2	OFF	Reset Count Count = 129
Relay 1	ON	ON OFF PULSE
Relay 2	ON	ON OFF PULSE
Relay 3	ON	ON OFF PULSE
Relay 4	OFF	ON OFF PULSE
Relay 5	ON	ON OFF PULSE
Relay 6	OFF	ON OFF PULSE
Relay 7	ON	ON OFF PULSE
Relay 8	OFF	ON OFF PULSE
Relay 9	ON	ON OFF PULSE
Relay 10	ON	ON OFF PULSE
Sensor 1	81.9 °F	
Sensor 2	76.4 °F	
Sensor 3	82.2 °F	
Current Time: Mon, 15 Nov 2010 10:59:01		

WebRelay-10 Plus Control Page

Setup

Event 6

Current Date/Time: 11/15/2010 10:42:51

Schedule #: 0

Description:

Start Date: (Calendar view for November 2010)

Start Time (HH:MM:SS): 00:00:00

Period: 0 Days (Enter 0 to disable event.)

Days: Sun Mon Tue Wed Th Fri Sat

Count: 0 (Enter 0 for continuous occurrence.)

Action: no action

Affected Relays: 1 2 3 4 5 6 7 8 9 10

Pulse Duration: 1.5 secs

*Select a period of one day in order to specify days on which the event will occur.

Cancel Update

Event Scheduling Page

APPLICATIONS & SPECS

Scheduled Lighting Control

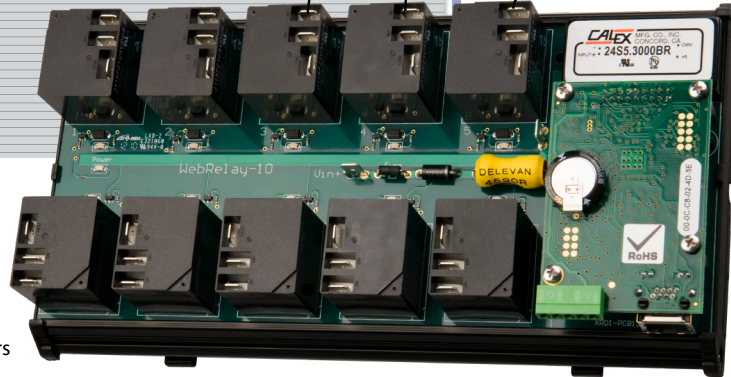
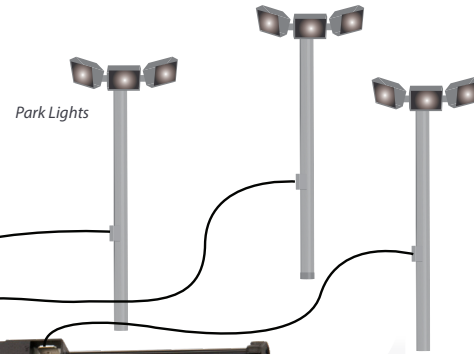
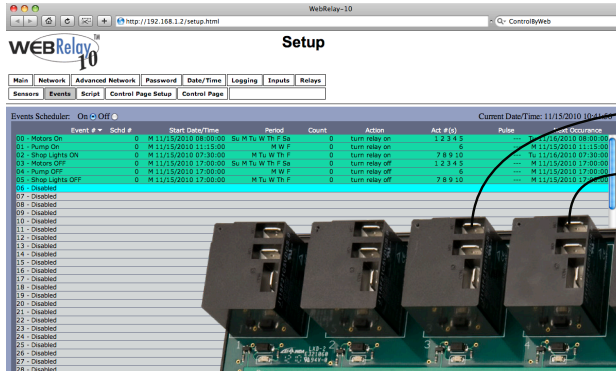

Models:

- X-WR-10R12-IP

Power Requirements

- Voltage: 10-36VDC
- Max Current: 53mA - 1.2A
- Note: Current based upon voltage applied and device settings. See users manual for complete breakdown.

Relay Contacts

- Number of Relays: 10
 - N.O.
 - 40A @ 240VAC resistive
 - 30A @ 277VAC General Purpose
 - 2hp @ 250VAC
 - N.C.
 - 30A @ 240VAC, 30VDC resistive
 - 20A @ 277VAC General Purpose
 - 1-1/2 hp @ 250VAC
- Contact Type: SPDT (Form 1C)
- Load Type: General Purpose
- Contact Resistance: < 30 milliohms initial
- Contact Material: AgSnO2
- Electrical Life: 100K cycles (Typical)
- Mechanical Life: 10M cycles (Typical)
- Environmental Rating: Over voltage Category II, Pollution Degree 2
- Relay Modes: ON/OFF or Pulse
- Pulse Timer Duration: 0.1 to 86,400 Seconds (1-day)
- Relay Connections: 1/4" Tab Terminals

Digital Inputs

- Number of Inputs: 2
- Type: Non-Isolated
- Voltage Range: 0-5VDC
- Current: 47K Pullup
- Minimum Hold Time: 20ms
- Input Isolation: Non-Isolated
- Input Functions: Counters, Email Alerts, SNMP Traps
- Maximum Count: 32-bit
- Max Count Rate: 25Hz
- Edge Trigger: Rising, Falling or Both

Temperature Sensors

- Maximum Number of Sensors: 8
- Type: 1-Wire Dallas Semiconductor DS18B20
- Temperature Range: -67°F to 257°F (-55°C to +125°C)
- Accuracy: ±0.5°C (from -10°C to +85°C)
- Sensor Functions: Monitor Temperature, Log Temperature, Email Alerts, SNMP Traps
- Humidity Type: Xytronix Model X-DTHS-WM wall mount sensor
- Humidity Range: 0-100% RH
- Accuracy: ±1.8%

Real-Time Clock

- Manual or NTP(Network Time Protocol) setup
- NTP Sync Period: Once, Daily, Weekly, On Power-up
- Auto Daylight Savings Adjustment
- Battery (capacitor) Power Backup

Capacitor Power Backup

- Backup Functions: Retain Real-Time Clock, External Variables, Relay State
- Backup Duration: 3 days minimum

Network

- Type: 10/100 Base-T Ethernet Port
- Setup: Static IP address assignment or DHCP, HTTP port selectable

LED Indicators

- Number of LEDs: 13
 - Power on
 - Relay coil energized 1-10
 - Network linked
 - Network activity

Additional Applications

- ✓ Automation Controller
- ✓ Industrial Automation
- ✓ Car Wash Industry
- ✓ More...

Physical

- Size:
 - 9.125in (232mm) wide
 - 4.25in (126mm) tall
 - 2.425in (62mm) deep
- Weight: 22 oz (626 grams)
- Enclosure Material: PVC
- Enclosure Flame Rating: UL94 V1
- Operating Temperature: -40°F to 150°F (-40°C to 65.5°C)

Protocols

- HTTP, XML, Modbus, SNMP, SMTP, Remote Services, and Remote Monitoring

Logging

- Log File Size: 512K max 17900 logs
- Storage: Nonvolatile Flash
- Buffer Architecture: Circular Buffer
- Log data can be periodically read and stored on a computer

Password Settings

- Password protection on setup page: Yes
- Password protection on control page: Optional
- Password Encoding: Base 64
- Max Password Length: 10 Characters

Electromagnetic Compliance

- IEC CISPR 22, CISPR 24
- FCC 47CFR15 (Class B)
- EN55024 ITE Immunity (2010)
- EN55022 Emissions (2010)



Product Safety Compliance

- IEC 61010-1



WebSwitch™ Remote Power Switch is the ideal solution for remote reboot and many remote power control applications. WebSwitch™ has two power outlets which can be independently controlled using a web browser.

It is completely self-contained and includes a built-in web server, so no external servers, services, or subscriptions are required.

In addition to remote control, WebSwitch™ has an automatic reboot controller which can be configured to reboot computers or network devices when they become unresponsive.

WebSwitch™ is available in two models, WebSwitch™ and WebSwitch Plus™.

Both models are engineered to provide excellent performance for many years while running 24/7. You can have confidence using WebSwitch™ when your critical applications demand reliability and integrity.

Features:

- Control from a standard web browser - no special software required.
- Automatic Reboot, use to reboot devices when ping responses fail.
- Built-in web server provides direct access to device; no external servers, services or subscriptions required.
- Supports HTTP, SNMP, and Modbus TCP/IP.
- "Remote Services" can be used to initiate connection with external servers.
- Password protection.
- IP filter provides simple firewall.
- Selectable TCP Ports.
- 10/100 Mbps Ethernet connectivity.
- Field re-programmable; install firmware updates when available.
- Attractive, rugged enclosure made of flame resistant plastic.
- Operates worldwide (100-240V AC; 50/60Hz).
- Wall mountable or optional rack mounting kit available.

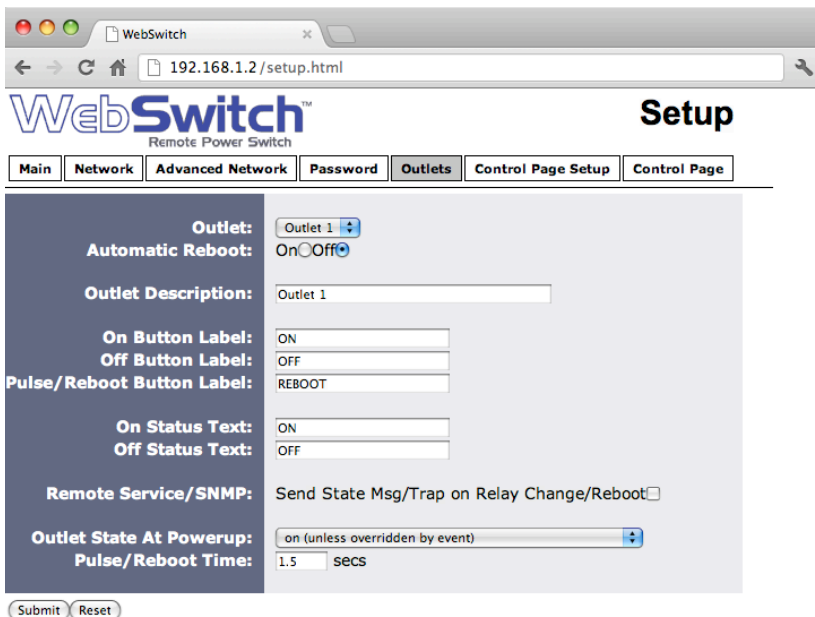

Outlets Options

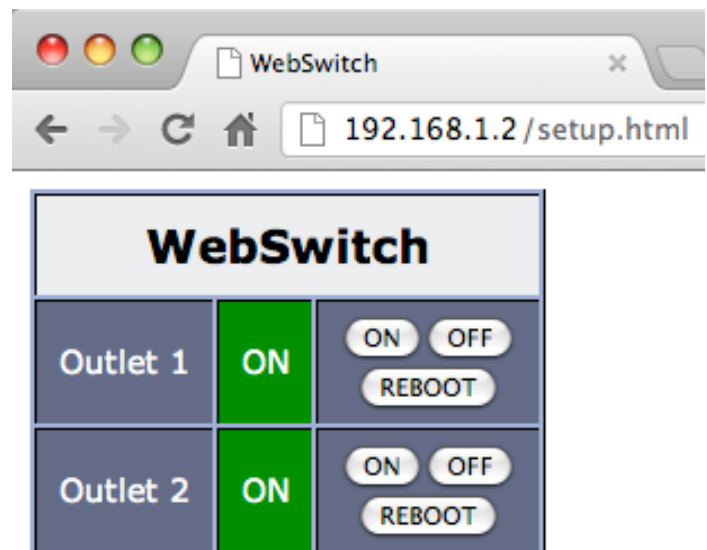

Control Page

APPLICATIONS & SPECS

Automatic/Remote Reboot for Servers

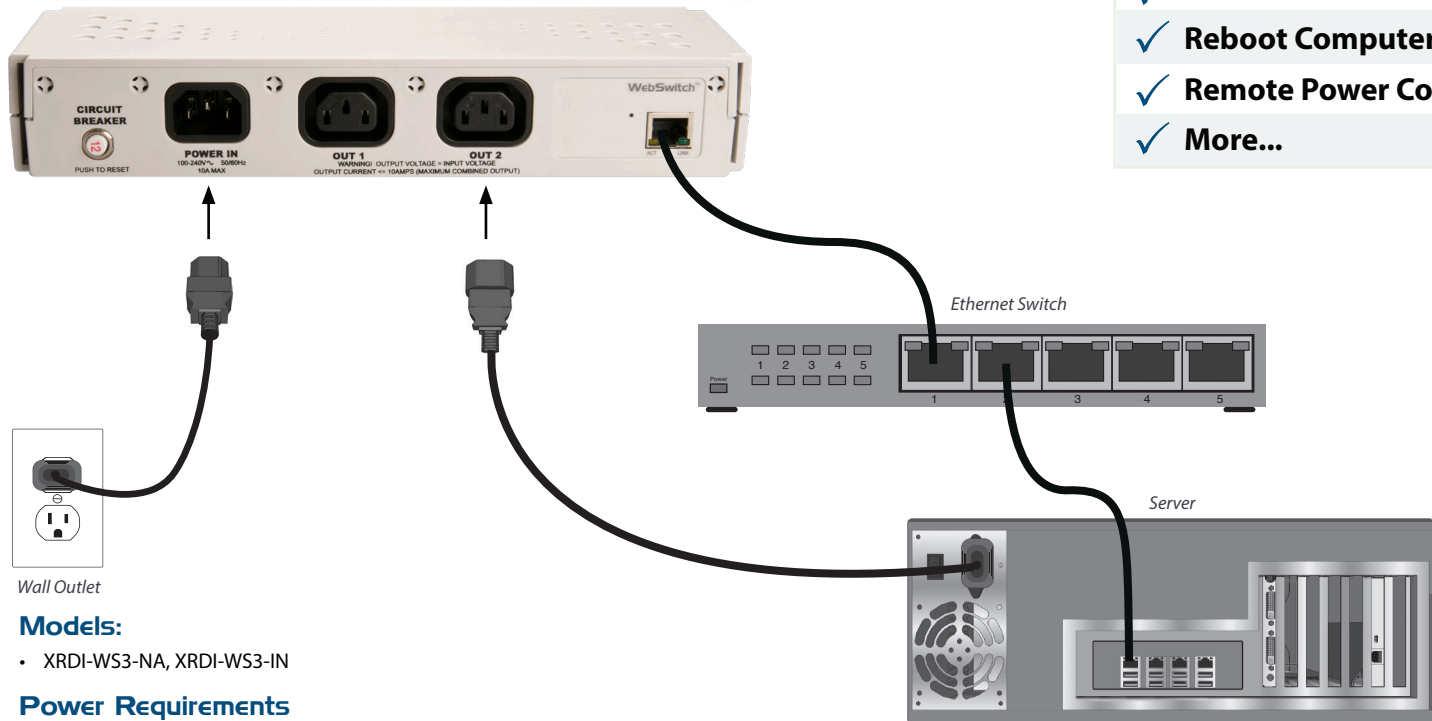

Additional Applications

- ✓ Reboot Network Devices
- ✓ Reboot Computers
- ✓ Remote Power Control
- ✓ More...

Models:

- XRDI-WS3-NA, XRDI-WS3-IN

Power Requirements

- Voltage: 100-240V AC (47-63Hz)
- Input Frequency: 47-63Hz
- Input Connector: IEC 320 Appliance Connector (C14 Male)
- Max Current: 10A *(DO NOT USE WEBSWITCH TO CONTROL MORE THAN 10 AMPS)*

Relay Contacts

- Number of Relays: 2
- Relay Connector: IEC C13 Female
- Contact Type: SPDT (Form 1C)
- Load Type: General Purpose
- Contact Resistance: < 30 milliohms initial
- Contact Material: AgSnO2
- Electrical Life: 100K cycles (Typical)
- Mechanical Life: 10M cycles (Typical)
- Environmental Rating: Over voltage Category II, Pollution Degree 2
- Relay Modes: ON/OFF or Pulse/Reboot
- Pulse Timer Duration: 0.1 to 86,400 Seconds (1-day)

Real-Time Clock

- Manual or NTP (Network Time Protocol) setup
- NTP Sync Period: Once, Daily, Weekly, On Power-up
- Auto Daylight Savings Adjustment
- Battery (capacitor) Power Backup

Network

- Type: 10/100 Base-T Ethernet Port
- Setup: Static IP address assignment, HTTP port selectable

Connectors

- Output Connectors: IEC 320 Appliance Connector (C13 Female)
- Network: 8-pin RJ-45

LED Indicators

- Number of LEDs: 5
 - Power on
 - Out On 1-2
 - Network linked
 - Network activity

Physical

- Operating Temperature: -4°F to 104°F (-20°C to 40°C)
- Size:
 - 10.65 inches (27.11 cm) wide
 - 1.75 inches (4.44 cm) tall
 - 3.29 inches (8.36 cm) deep
- Weight: 1 lb. 3 oz. (542 grams)
- Enclosure Material: Lexan 940 Polycarbonate Plastic
- Enclosure Flame Rating: UL94 V0

Protocols

- HTTP, XML, Modbus, SNMP, Remote Services

Password Settings

- Password protection on setup page: Yes
- Password protection on control page: Optional
- Password Encoding: Base 64
- Max Password Length: 13 Characters

Electromagnetic Compliance:

- IEC CISPR 22, CISPR 24
- FCC 47CFR15
- EU EN55024, EN55022
- EN55022:2006: Class B
- EN61000-3-2
- EN61000-3-3
- EN55024:2006
- IEC 61000-4-2
- IEC 61000-4-3
- IEC 61000-4-4
- IEC 61000-4-5
- IEC 61000-4-6
- IEC 61000-4-8
- IEC 61000-4-11
- ITE-Class B



Product Safety Compliance

- CAN/CSA-C22.2 No. 60950-1-03 First Edition
- IEC 61010-1



WebSwitch Plus™ includes all the features of WebSwitch™ as well as additional features such as remote temperature monitoring, discrete inputs, event scheduling, logging, and email alerts. This provides a more complete solution for remotely controlling servers and monitoring their environment.



WebSwitch with optional Rack Mount Kit

Features:

- Up to four temperature and/or humidity sensors can be added for environmental monitoring (one temperature sensor included).
- Dry-contact sensors or switches can be connected for local control of outlets or for monitoring external devices.
- Real-time clock, can automatically adjust for daylight savings time, sync with NTP server.
- Added relay contact protection.
- Event scheduler with yearly calendar.
- Customizable email alerts.
- Logging: Log outlet changes, automatic reboots, high/low temperatures, network traffic, and more.
- System log provides detailed diagnostic information.
- Simple scripts can be written in BASIC for advanced functionality.
- Configure manually or with DHCP.

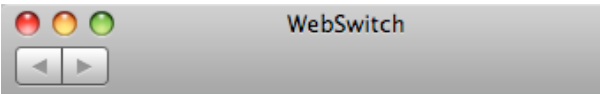

WebSwitch		
Outlet 1	ON	ON OFF REBOOT
Outlet 2	OFF	ON OFF REBOOT
Input 1	OFF	
Input 2	OFF	
Sensor 1	74.3 °F	
Sensor 2	73.5 °F	
Sensor 3	38.6 %RH	
Current Time: Tue, 01 Jun 2010 09:29:39		

Control Page

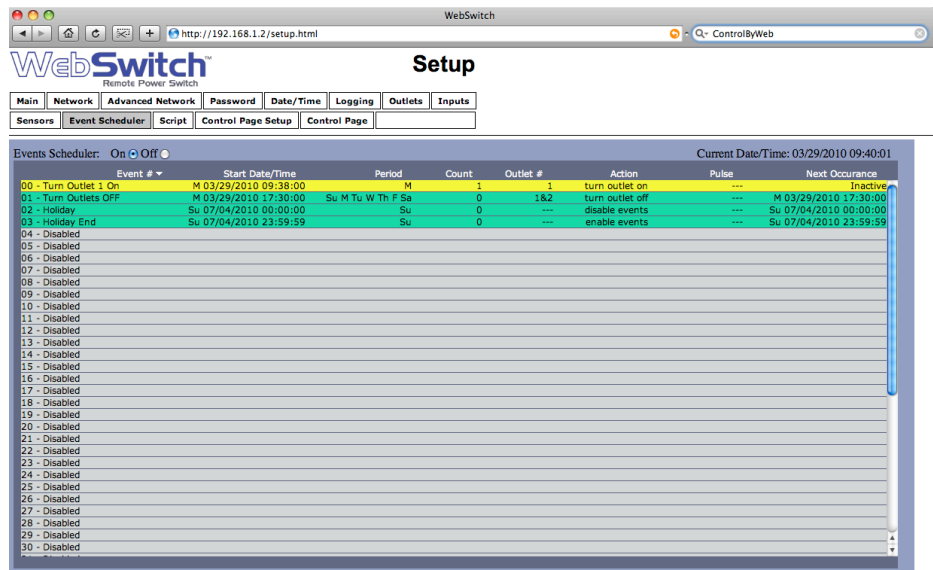

Events Tab

APPLICATIONS & SPECS

Environmental Monitoring,
Automatic/Remote Reboot for Servers

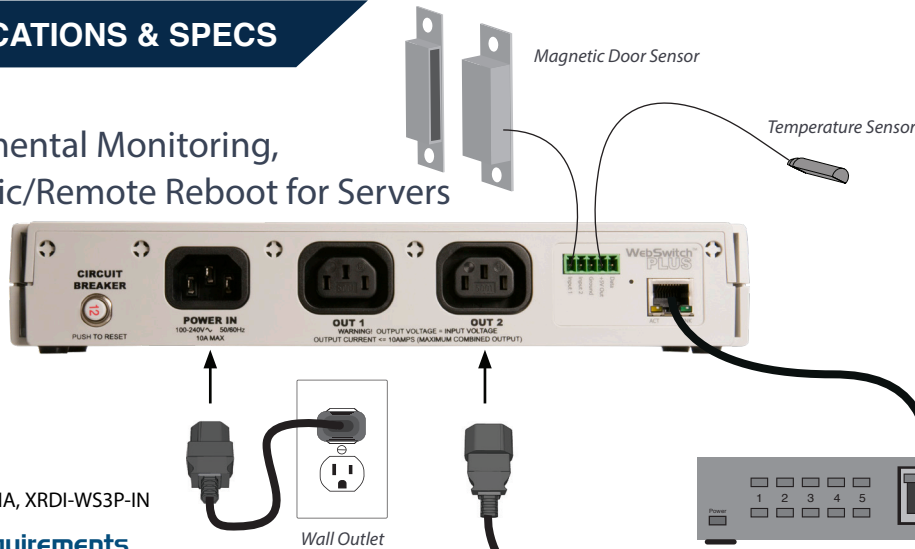

Additional Applications

- ✓ Reboot Network Devices
- ✓ Reboot Computers
- ✓ Remote Power Control
- ✓ More...

Models:

- XRDI-WS3P-NA, XRDI-WS3P-IN

Power Requirements

- Voltage: 100-240V AC (47-63Hz)
- Input Frequency: 47-63Hz
- Input Connector: IEC 320 Appliance Connector (C14 Male)
- Max Current: 10A *(DO NOT USE WEBSWITCH TO CONTROL MORE THAN 10 AMPS)*

Relay Contacts

- Number of Relays: 2
- Relay Connector: IEC C13 Female
- Contact Type: SPDT (Form 1C)
- Load Type: General Purpose
- Contact Resistance: < 30 milliohms initial
- Contact Material: AgSnO2
- Electrical Life: 100K cycles (Typical)
- Mechanical Life: 10M cycles (Typical)
- Environmental Rating: Over voltage Category II, Pollution Degree 2
- Relay Modes: ON/OFF or Pulse/Reboot
- Pulse Timer Duration: 0.1 to 86,400 Seconds (1-day)

Digital Inputs

- Number of Inputs: 2
- Type: Non-Isolated
- Voltage Range: 0-5VDC
- Current: 47K Pullup
- Minimum Hold Time: 20ms
- Input Isolation: Non-Isolated
- Input Functions: Emails Alerts, SNMP Traps

Temperature Sensors

- Maximum Number of Sensors: 3
- Type: Dallas Semiconductor DS18B20
- Temperature Range: -67°F to 257°F (-55°C to +125°C)
- Accuracy: ±0.5°C (from -10°C to +85°C)
- Sensor Functions: Monitor Temperature, Log Temperature, Email Alerts, SNMP Traps
- Humidity Type: Xytronix Model X-DTHS-WM wall mount sensor
- Humidity Range: 0-100% RH
- Accuracy: ±1.8%

Real-Time Clock

- Manual or NTP (Network Time Protocol) setup
- NTP Sync Period: Once, Daily, Weekly, On Power-up
- Auto Daylight Savings Adjustment
- Battery (capacitor) Power Backup

Capacitor Power Backup

- Backup Functions: Retain Real-Time Clock, External Variables, Outlet State.
- Backup Duration: 3 days minimum

Network

- Type: 10/100 Base-T Ethernet Port
- Setup: Static IP address assignment or DHCP, HTTP port selectable

Connectors

- Output Connectors: IEC 320 Appliance Connector (C13 Female)
- Network: 8-pin RJ-45
- Digital Inputs & Temperature: 5-Position Removable

LED Indicators

- Number of LEDs: 5
 - Power on
 - Out On 1-2
 - Network linked
 - Network activity

Physical

- Operating Temperature: -4°F to 104°F (-20°C to 40°C)
- Size:
 - 10.65 inches (27.11 cm) wide
 - 1.75 inches (4.44 cm) tall
 - 3.29 inches (8.36 cm) deep
- Weight: 1 lb. 3 oz. (542 grams)
- Enclosure Material: Lexan 940 Polycarbonate Plastic
- Enclosure Flame Rating: UL94 V0

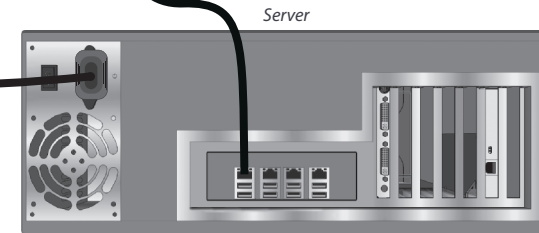

Protocols

- HTTP, XML, Modbus, SNMP, Remote Services

Password Settings

- Password protection on setup page: Yes
- Password protection on control page: Optional
- Password Encoding: Base 64
- Max Password Length: 13 Characters

Electromagnetic Compliance:

- IEC CISPR 22, CISPR 24
- FCC 47CFR15
- EU EN55024, EN55022
- EN55022:2006: Class B
- EN61000-3-2
- EN61000-3-3
- EN55024:2006
- IEC 61000-4-2
- IEC 61000-4-3
- IEC 61000-4-4
- IEC 61000-4-5
- IEC 61000-4-6
- IEC 61000-4-8
- IEC 61000-4-11
- ITE-Class B



Product Safety Compliance

- CAN/CSA-C22.2 No. 60950-1-03 First Edition
- IEC 61010-1

	Outputs	Inputs	Temperature Monitoring		Humidity Monitoring		Real-Time Clock		Scheduling	Logging	Email Notifications	Automatic Reboot	Input Counters	Remote Relays	Supported Scripts	Supported Protocols	Enclosure	Power Supply
WebRelay	1 Relay 240VAC, 30VDC 12A	1 Digital	-	-	-	-	-	-	-	•	-	1	-	-	HTTP, XML, Modbus TCP/IP	DIN Rail or Wall-Mount	9-28VDC POE and/or 9-28VDC	
WebRelay Wireless	1 Relay 277VAC, 30VDC 12A	1 Digital	1-4		•	-	•	•	-	•	-	1	BASIC	HTTP, XML, Modbus/TCP, Remote Services	DIN Rail or Wall-Mount	9-28VDC		
X-401	2 Relays 28VAC, 24VDC 3A	2 Digital	-		•	•	•	•	•	•	2	Up to 100	BASIC	HTTP, HTTPS, SSL, XML, Modbus TCP/IP, SNMP, SMTP, Remote Services	DIN Rail or Wall-Mount	9-28VDC POE and/or 9-28VDC		
X-404	Up to 32 Modbus RS-485 Sensors	-	1-16		•	•	•	•	-	-	-	Up to 100	BASIC	HTTP, HTTPS, SSL, XML, Modbus TCP/IP, SNMP, SMTP, Remote Services	DIN Rail or Wall-Mount	9-28VDC		
X-405	-	-	1-16		•	•	•	•	-	-	-	Up to 100	BASIC	HTTP, HTTPS, SSL, XML, Modbus TCP/IP, SNMP, SMTP, Remote Services	DIN Rail or Wall-Mount	9-28VDC POE and/or 9-28VDC		
X-406	-	-	1-64		•	•	•	•	-	-	-	Up to 100	BASIC	HTTP, HTTPS, SSL, XML, Modbus TCP/IP, SNMP, SMTP, Remote Services	DIN Rail or Wall-Mount	9-28VDC POE and/or 9-28VDC		
X-408	-	8 Digital	-		•	•	•	•	-	•	-	Up to 100	BASIC	HTTP, HTTPS, SSL, XML, Modbus TCP/IP, SNMP, SMTP, Remote Services	DIN Rail or Wall-Mount	9-28VDC POE and/or 9-28VDC		
X-410	4 Relays 28VAC, 24VDC 1A	4 Digital 4-26VDC	1-16		•	•	•	•	•	•	-	Up to 100	BASIC	HTTP, HTTPS, SSL, XML, Modbus TCP/IP, SNMP, SMTP, Remote Services	DIN Rail or Wall-Mount	9-28VDC POE and/or 9-28VDC		
X-418	-	8 Analog ±1.28V, ±2.56V, ±5.12V, ±10.24V	-		•	•	•	•	-	-	-	Up to 100	BASIC	HTTP, HTTPS, SSL, XML, Modbus TCP/IP, SNMP, SMTP, Remote Services	DIN Rail or Wall-Mount	9-28VDC POE and/or 9-28VDC		
X-420	2 Digital I/Os 4 Analog Inputs ±1.28V, ±2.56V, ±5.12V, ±10.24V 1 Frequency Input		1-16		•	•	•	•	-	•	-	Up to 100	BASIC	HTTP, HTTPS, SSL, XML, Modbus TCP/IP, SNMP, SMTP, Remote Services	DIN Rail or Wall-Mount	9-28VDC POE and/or 9-28VDC		
WebRelay-Quad	4 Relays 28VAC, 24VDC 3A	-	-	-	-	-	-	-	-	-	-	-	-	-	HTTP, XML, Modbus TCP/IP	DIN Rail Wall-Mount	9-28VDC POE/5VDC	

	Outputs	Inputs	Temperature Monitoring	Humidity Monitoring	Real-Time Clock	Scheduling	Logging	Email Notifications	Automatic Reboot	Input Counters	Remote Relays	Supported Scripts	Supported Protocols	Enclosure	Power Supply
X-300	3 Relays 28VAC, 24VDC 3A		1-8	•	•	•	•	-	-	3	BASIC	HTTP, XML, Modbus TCP/IP, SNMP, SMTP, Remote Services	DIN Rail Wall-Mount	9-28VDC POE/5VDC	
X-317	5 Analog Outputs	-	-	-	-	-	-	-	-	-	-	HTTP, XML, Modbus TCP/IP, SNMP	DIN Rail Wall-Mount	9-28VDC	
X-332	16 Relays 30VDC, 30VAC 2A	16 Digital 4 Analog	1-4	•	•	•	•	-	2	16	BASIC	HTTP, XML, Modbus TCP/IP, SNMP, SMTP, Remote Services	DIN Rail Wall-Mount Shelf Mount	9-28VDC	
X-400	Expandable I/O via expansion modules		1-16	•	•	•	•	•		Up to 100	BASIC	HTTP, HTTPS, SSL, XML, Modbus TCP/IP, SNMP V1,2C,V3, SMTP	DIN Rail Wall-Mount	9-28VDC	
X-600M	Expandable I/O via expansion modules		1-32	•	•	•	•	•		Up to 1024	LUA	HTTP, XML, Modbus TCP/IP, SNMP, SMTP, Remote Services	DIN Rail Wall-Mount	9-28VDC	
X-11s	2 Relays 277VAC, 110VDC, 20A	-	-	<i>This is an expansion module compatible with the X-400 or X-600M Controller. See the X-400 or X-600M features.</i>								DIN Rail Wall-Mount	Powered via expansion bus from X-400 or X-600M		
X-12s	8 Relays 125VAC 30VDC 2.5A	-	-	<i>This is an expansion module compatible with the X-400 or X-600M Controller. See the X-400 or X-600M features.</i>								DIN Rail Wall-Mount	Powered via expansion bus from X-400 or X-600M		
X-13s	-	-	2 Thermocouple Type K	<i>This is an expansion module compatible with the X-400 or X-600M Controller. See the X-400 or X-600M features.</i>								DIN Rail Wall-Mount	Powered via expansion bus from X-400 or X-600M		
X-15s	-	8 Digital	-	<i>This is an expansion module compatible with the X-400 or X-600M Controller. See the X-400 or X-600M features.</i>					8	<i>See X-400 or X-600M features.</i>			DIN Rail Wall-Mount	Powered via expansion bus from X-400 or X-600M	
X-16s	-	8 Analog	-	<i>This is an expansion module compatible with the X-400 or X-600M Controller. See the X-400 or X-600M features.</i>								DIN Rail Wall-Mount	Powered via expansion bus from X-400 or X-600M		
X-17s	4 Relays 125VAC, 30VDC 2.5A	4 Digital	-	<i>This is an expansion module compatible with the X-400 or X-600M Controller. See the X-400 or X-600M features.</i>					4	<i>See X-400 or X-600M features.</i>			DIN Rail Wall-Mount	Powered via expansion bus from X-400 or X-600M	
X-18s	10 Relays 277VAC, 30VDC 30A	-	-	<i>This is an expansion module compatible with the X-400 or X-600M Controller. See the X-400 or X-600M features.</i>								DIN Rail	9-28VDC		

	Outputs	Inputs	Temperature Monitoring	Humidity Monitoring	Real-Time Clock	Scheduling	Logging	Email Notifications	Automatic Reboot	Input Counters	Remote Relays	Supported Scripts	Supported Protocols	Enclosure	Power Supply
X-19s	16 Relays 30VDC, 30VAC 2A	16 Digital 4 Analog	-	-	<i>This is an expansion module compatible with the X-400 or X-600M Controller. See the X-400 or X-600M features.</i>								DIN Rail	9-28VDC	
X-20s	6 Relays 277VAC, 30VDC 15A	6 Digital	-	-	<i>This is an expansion module compatible with the X-400 or X-600M Controller. See the X-400 or X-600M features.</i>								DIN Rail	9-28VDC	
X-21s	4 Relays 125VAC, 28VDC 2.5A	-	-	-	<i>This is an expansion module compatible with the X-400 or X-600M Controller. See the X-400 or X-600M features.</i>								DIN Rail	Powered via expansion bus from X-400 or X-600M	
X-22s	-	8 Analog	-	-	<i>This is an expansion module compatible with the X-400 or X-600M Controller. See the X-400 or X-600M features.</i>								DIN Rail	Powered via expansion bus from X-400 or X-600Mv	
XW-110	-	-	1	-	-	-	-	•	-	-	1	-	HTTP, XML, SMTP	Wall-Mount	5 VDC Wall Transformer
XW-110 Plus	-	-	3	-	-	-	•	•	-	-	1	-	HTTP, XML, Modbus TCP/IP, SMTP, Remote Services	Wall-Mount	5 VDC Wall Transformer
XW-111	-	2 Digital	-	-	-	-	-	•	-	-	2	-	HTTP, XML, SMTP	Wall-Mount	5 VDC Wall Transformer
XW-112	-	1 Digital	-	-	-	-	-	•	-	-	1	-	HTTP, XML, SMTP	Wall-Mount	5 VDC Wall Transformer
WebRelay-10	10 Relays 277VAC, 30VDC 15A	-	-	-	-	-	-	-	-	-	-	BASIC	HTTP, XML, Modbus TCP/IP, SNMP, SMTP, Remote Services	DIN Rail	9-28 VDC
WebRelay-10 Plus	10 Relays 277VAC, 30VDC 15A	2 Digital	1-8	•	•	•	•	-	-	-	-	BASIC	HTTP, XML, Modbus TCP/IP, SNMP, SMTP, Remote Services	DIN Rail	9-28 VDC
WebSwitch	2 AC Outlets 10A Max	-	-	-	-	-	-	-	•	-	-	-	HTTP, XML, Modbus TCP/IP, SNMP, Remote Services	Rack Mount Wall-Mount Shelf Mount	100-240VAC
WebSwitch Plus	2 AC Outlets 10A Max	2 Digital	1-3	•	•	•	•	•	-	-	-	BASIC	HTTP, XML, Modbus TCP/IP, SNMP, SMTP, Remote Services	Rack Mount Wall-Mount Shelf Mount	100-240VAC

Trademark and Copyright Information

This document is Copyright ©2010-2021 by Xytronix Research & Design, Inc. All rights reserved.

WebSwitch™, WebRelay™, ControlByWeb™, and Xytronix Research & Design™ are trademarks of Xytronix Research & Design™, Inc. 2005-2021.

All parts of these products and designs including but not limited to firmware, hardware design, schematics, PCB layout, concept, graphics, users manual, etc., are property of Xytronix Research & Design, Inc. ©2005-2021. These products may not be opened, disassembled, copied or reverse-engineered.

No part of this document may be reproduced or transmitted in any form or by any means, electronic or mechanical, including photocopying or scanning, for any purpose other than the personal use by the purchaser of these products. Xytronix Research & Design, Inc., assumes no responsibility for any errors that may appear in this document.

Whereas reasonable effort has been made to make the information in this document as useful and accurate as possible, Xytronix Research & Design, Inc. assumes no responsibility for the application, usefulness, or completeness of the information contained herein. Under no circumstance will Xytronix Research & Design, Inc. be responsible or liable for any damages or losses including direct, indirect, special, incidental, or consequential damages or losses arising from either the use of any information contained within this manual or the use of any products or services referenced in this document.

Xytronix Research & Design, Inc. reserves the right to change any product's features, specifications, documentation, warranties, fee schedules, and conditions at any time and without notice.

Warranty

XRDI warrants our Products to be free of defects in workmanship and material under normal use and service and to perform substantially in accordance with published XRDI specifications (subject to reasonable tolerances) for a period of five (5) years from the date of invoice. This five year warranty only applies to products shipped from XRDI (or an authorized XRDI distributor) on or after May 1, 2016 (products shipped before that date continue to have their original twelve (12) month warranty). This warranty includes all standard ControlByWeb products that are manufactured by XRDI (does not include sensors, power supplies, and products that are sold on the ControlByWeb web site but not manufactured by XRDI). Custom Products that are manufactured by XRDI are warranted for a period of twelve (12) months from the date of invoice. XRDI warrants functionality of Products as specified when shipped however XRDI cannot and does not guarantee or warrant ongoing compatibility with software, protocols, or devices that are developed or maintained by third parties such as web browsers, automation software, etc. During the warranty period, XRDI's obligation is limited to, at its option, either repair or replace Products that prove to be defective, which shall be the sole and exclusive remedy under this limited warranty. Section 10-b describes return procedures and shipping costs that are covered and not covered under this warranty.

Limitation

The foregoing warranty shall not apply to defects or damage resulting from improper use or misuse, neglect, shipping damage, unauthorized or improper repair, tampering, modification, improper connection, improper installation, or operation outside the electrical/environmental specifications for the product. Further, the warranty does not cover Acts of God, including but not limited to lightning, fire, flood, hurricanes, and tornadoes. This warranty does not cover damage to property, equipment, direct, indirect, consequential, or incidental damage (including damage for loss of business profit, business interruption, loss of data, and the like) arising out of the use or misuse of this product.

TO THE GREATEST EXTENT PERMITTED BY APPLICABLE LAW, UNDER NO CIRCUMSTANCES WILL THE LIABILITY OF XRDI TO THE BUYER OR ANY OTHER PARTY EXCEED THE ORIGINAL PURCHASE PRICE OF THE PRODUCT, REGARDLESS OF THE FORM OF THE CLAIM. No other warranty is expressed or implied. XRDI specifically disclaims the implied warranties or merchantability and fitness for a particular purpose.